

AIRTECH[®]

VACUUM

MEDICAL VACUUM SYSTEMS

NFPA 99C Compliant Medical Vacuum Systems Tank-Mounted Oil Flooded Rotary Vane

Airtech NFPA compliant Medical Vacuum Systems are manufactured and tested to *NFPA 99C standards. Each of our various medical systems utilize only the highest quality components and each system is provided with the following features:

- UL Listed NEMA 12 enclosed motor control center
 - UL listed through the door disconnect switches (5.1.3.6.6.3)*
 - Individual control transformers (5.1.3.6.6.3)*
 - Vacuum receiver by-pass assembly (5.1.3.6.5.2)*
 - ASME coded vacuum receiver (5.1.3.6.3)*
 - Lag alarm-audible alarm and indicator light (5.1.9.4.4)*
 - Dry contacts for remote monitoring to master alarm
- Optional: Motor control center with Ethernet/BMS capabilities-Consult Factory!



DUPLEX VERTICAL TANK MOUNTED
ROTARY VANE VACUUM PACKAGE

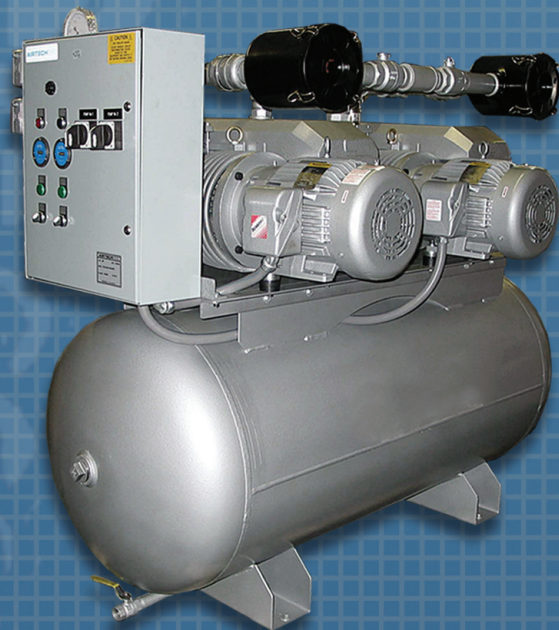

DUPLEX HORIZONTAL TANK MOUNTED
ROTARY VANE VACUUM PACKAGE

NFPA 99C Compliant Medical Vacuum Systems

Tank-Mounted Oil flooded Rotary Vane

Model	SCFM@19" HG Per Pump	HP	Tank (Gal.)	A	B	L	H	W	X	Y	Weight (Lbs.)	NO.	QUAN.	DESCRIPTION
SCS-L21-2TANV-NFPA	5.1	1.0	80	.75	.75	40	72	28	14.8	14.8	525	1	2	VACUUM PUMP
SCS-L25-2TANV-NFPA	7.3	1.5	80	1.25	1.25	42	72	30	14.8	14.8	650	2	2	ELECTRIC MOTOR
SCS-L40-2TANV-NFPA	11.0	2.0	80	1.25	1.25	42	72	32	14.8	14.8	675	3	1	TANK
SCS-L63-2TANV-NFPA	16.0	3.0	120	1.25	1.25	52	76	34	19.0	19.0	1,050	4	1	CONTROL PANEL
SCS-L100-2TANV-NFPA	24.5	5.0	120	1.50	1.25	52	76	35	19.0	19.0	1,100	A	1	AIR INLET
												B	2	AIR DISCHARGE

Note: Specifications are subject to change without notice. Please contact factory for specification updates.

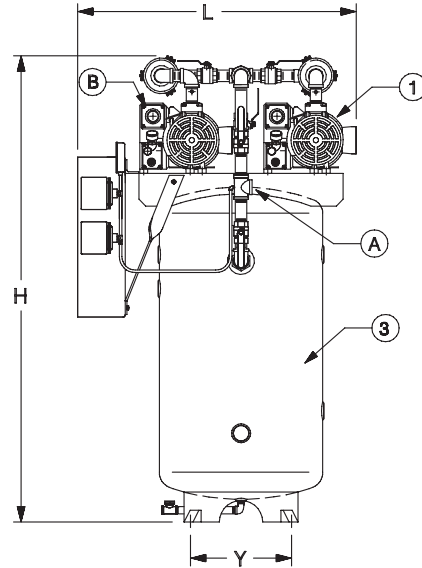
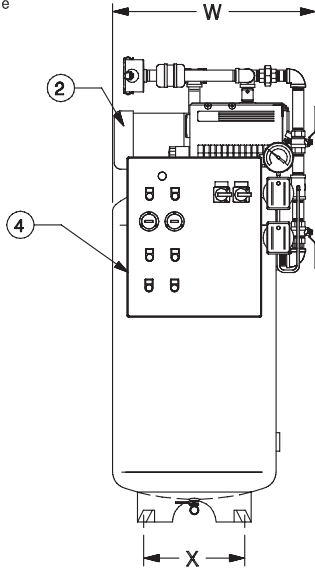

Model	SCFM@19" HG Per Pump	HP	Tank (Gal.)	A	B	L	H	W	X	Y	Weight (Lbs.)	NO.	QUAN.	DESCRIPTION
SCS-L21-2TAN-NFPA	5.1	1.0	80	.75	-----	67	60	20	18.5	36	550	1	2	VACUUM PUMP
SCS-L25-2TAN-NFPA	7.3	1.5	80	1.25	1.25	67	60	28	18.5	36	695	2	2	ELECTRIC MOTOR
SCS-L40-2TAN-NFPA	11.0	2.0	80	1.25	1.25	67	60	28	18.5	36	740	3	1	TANK
SCS-L63-2TAN-NFPA	16.0	3.0	120	1.25	1.25	74	66	30	18.25	42	975	4	1	CONTROL PANEL
SCS-L100-2TAN-NFPA	24.5	5.0	120	1.50	1.25	74	66	30	18.25	42	1,025	A	1	AIR INLET
SCS-L160-2TAN-NFPA	40.6	5.0	200	1.50	1.5	80	72	36	28	38	1,645	B	2	AIR DISCHARGE
SCS-L230-2TAN-NFPA	55.3	7.5	200	1.50	1.5	80	72	37	28	38	1,785			
SCS-L250D-2TAN-NFPA	64.1	10.0	200	1.50	2	80	72	43	28	38	1,900			

Note: Specifications are subject to change without notice. Please contact factory for specification updates.

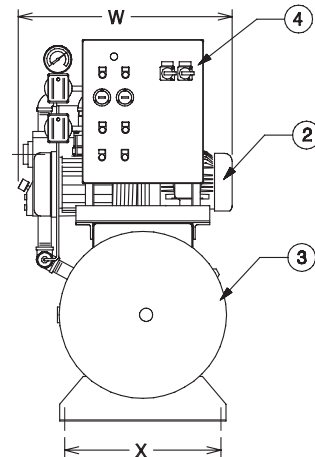
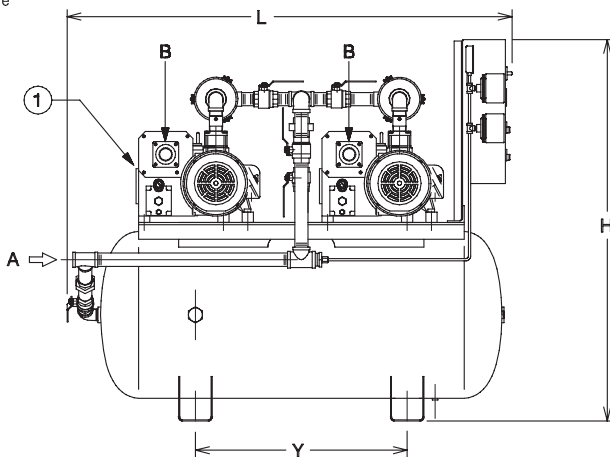

AIRTECH EAST
 301 Veterans Blvd
 Rutherford, NJ 07070
 Tel: (888) 222-9940
 Fax: (201) 569-1696
 airtech@airtechusa.com

AIRTECH SOUTH
 2121 Newmarket Pkwy. Suite 110
 Marietta, GA 30067
 Tel: (770) 690-0700
 Fax: (770) 690-0709
 airtechsouth@airtechusa.com

AIRTECH WEST
 42 Digital Drive, Suite 9
 Novato, CA 94949
 Tel: (415) 382-9000
 Fax: (415) 382-9700
 airtechwest@airtechusa.com