

FEATURES

- o Composite vane material for long life
- o Oil level sight glass
- o Vibraton isolators
- o Anti-suck back valve
- o Integral exhaust filters
- o TEFC high-efficiency tri-voltage motor (208-230-460V 50/60)
- o Wire mesh inlet screen



Airtech's L-Series rotary vane oil-flooded vacuum pump is a real workhorse. Reliability and durability are ensured by its simple design. Our L-Series Pump has integral exhaust filters, vibration isolators, and composite vane material which promotes longevity. The Airtech pump has an operating capacity range of 7-460 CFM while obtaining an end vacuum of 0.5 Torr.

PERFORMANCE CURVES

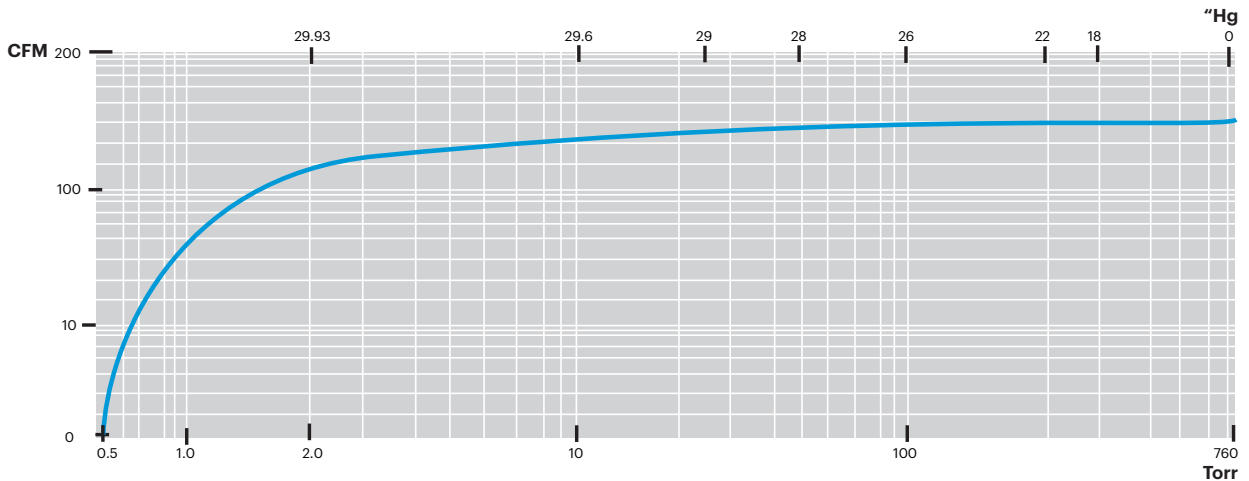

POWER CONSUMPTION

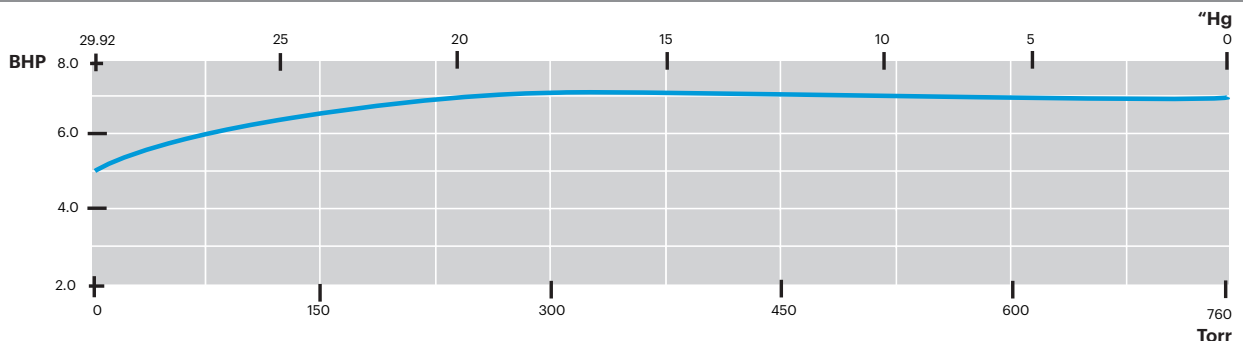

AIRTECH, INC.

RUTHERFORD, NJ 07070
 WWW.AIRTECHUSA.COM
 TEL: (888) 222-9940
 FAX: (201) 569-1696

Specifications are subject to change without notice. Please contact factory for specification updates.

DIMENSIONS (INCHES)

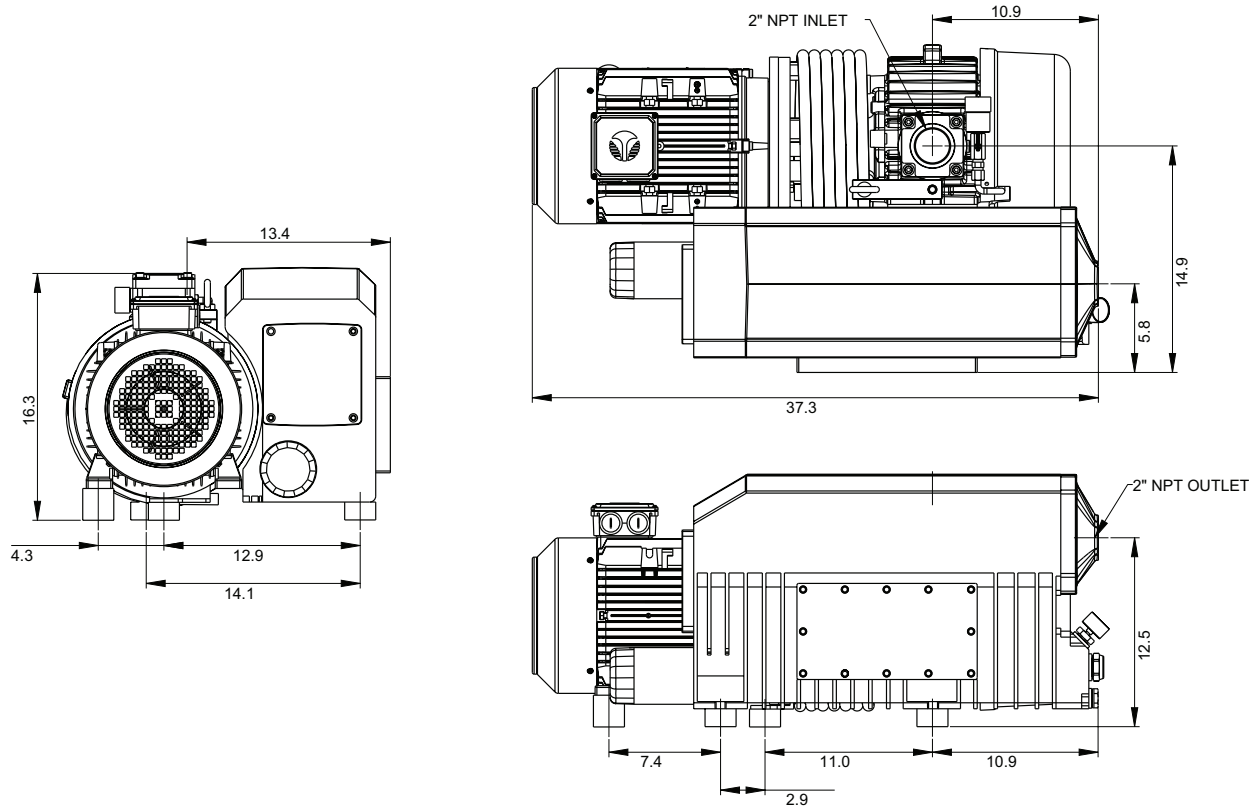

PERFORMANCE DATA

Model	L 160C
Free Air Displacement [CFM]	130
Motor Capacity (HP)	7.5
Speed (RPM)	1725
Sound Level [dB (A)]	74
End Vacuum (Torr)	0.5
Weight with motor (lbs.)	390
Oil Quantity (Qts.)	7

AIRTECH, INC.

RUTHERFORD, NJ 07070
 WWW.AIRTECHUSA.COM
 TEL: (888) 222-9940
 FAX: (201) 569-1696