



## Installation and Operating Manual

### L-Series Vacuum Pumps

#### Covering Models:

L12  
L21  
L25  
L40  
L40B  
L63  
L100  
L160B  
L160C  
L230B  
L250D  
L250E  
L305  
L305B

# **INSTALLATION & OPERATING MANUAL**

## **L-SERIES SINGLE STAGE ROTARY VANE VACUUM PUMPS**

L12 -L305B

Please read the manual before operating the vacuum pump.

### **TABLE OF CONTENTS**

#### **1.0 INSTALLATION**

- 1.1 Unpacking
- 1.2 Location
- 1.3 Power Requirements
- 1.4 Vacuum Connections
- 1.5 Oil Filling

#### **2.0 OPERATION**

- 2.1 Start-up
- 2.2 Stopping the pump
- 2.3 Gas Ballast

#### **3.0 MAINTENANCE**

- 3.1 Pump Oil (level/type/quantity/change)
- 3.2 Inline (inlet) Filter
- 3.3 Exhaust Filter
- 3.4 Maintenance Chart
- 3.5 Overhaul Kit and Accessories

#### **4.0 PROBLEM SOLVING**

#### **5.0 MOTOR AND ELECTRICAL DATA**

#### **6.0 TECHNICAL DATA**

#### **7.0 TYPICAL L-SERIES ASSEMBLY**

## INSTALLATION AND OPERATING MANUAL

This manual is written to cover L-Series Model vacuum pumps. The model number is stamped into the nameplate.

The number will appear as follows: LXXX-GX.

Please identify the model number and serial number when ordering parts.

### 1.0 INSTALLATION

#### 1.1 Unpacking

Inspect the box and pump carefully for any signs of damage incurred in transit. Since all pumps are ordinarily shipped F.O.B. from our factory or regional warehouse, such damage is normally the responsibility of the carrier and should be reported to them.

The vacuum pump is bolted to the skid with studs that are connected through the rubber feet of the pump. Remove the nuts from the underside of the crate and remove the pump. Unscrew the studs from the rubber feet.

The inlet and exhaust of the pump are covered with plastic caps to prevent dirt and other foreign substances from entering the pump. Leave these caps in place until you are ready to pipe the pump to your equipment.

#### 1.2 Location

Install the pump in a horizontal position on a level surface so that the pump is evenly supported on its rubber feet. Leave 12-18" of access around the pump to allow proper cooling. Also, adequate ventilation must be provided for the fans, radiator, and motor.

Allow access to the oil sight glass in order to inspect the oil level, and the exhaust port for easy access to change the exhaust filters.

Do not tip the pump over if filled with oil.

#### 1.3 Power Requirements

A schematic diagram for the electrical motor terminal connections is located in the junction box of the motor or on the motor nameplate.

The motor must be connected according to the electrical codes through a fused switch in order to protect the motor against electrical or mechanical overload conditions. The overload of the motor starter must be set at a level equal to the full load motor current listed on the motor nameplate.

If the pump is supplied with a motor starter, it is preset at the factory according to customer specifications. It is advisable to check that these settings are in line with the voltage at your location. If the voltage is different, please contact Airtech for motor and starter information.

Correct direction of rotation is marked by an arrow on the motor fan housing and is counterclockwise when looking at the motor from the motor's fan side.

**After electrical connections have been made, but prior to filling with oil, the rotation of the motor should be checked. If backward, reverse any two leads of the three at the power connection.**

## 1.4 Vacuum Connections

Use a pipe size that is at least the size of the pump inlet connections. Smaller lines result in a reduced pump capacity.

Pumps operating in parallel on a common main line should have a manual or automatic operated shut-off valve or positive action check valve, installed in the suction line adjacent to the pump suction flange. The built-in anti-suck back valve should not be used as a shut-off valve for the vacuum system.

Remove the plastic protective cap from the inlet port prior to connection of the pump to the system.

Should process gas contain dust or other foreign particles, a suitable in line (inlet) filter should be connected to the inlet port. Consult Airtech Inc. for recommendations.

The vacuum piping should be designed to ensure that no liquids such as condensate or liquid carried over from the process can reach the pump. If this possibility exists, a knock-out liquid separator should be installed. Consult Airtech Inc. for recommendations.

If an exhaust manifold is connected, install a drip leg and drain near the pump exhaust to prevent exhaust condensation from entering the exhaust box. The following thread sizes are standard on the Airtech pumps:

Pump Model	Inlet Size	Exhaust Size
L12/L21	1/2" NPT2	Open Grid
L25/L40/L40B	1 1/4" NPT	1 1/4" NPT
L63/L100	1 1/4" NPT	1 1/4" NPT
L160/L230	2" NPT	1 1/2" NPT
L160C/L250D/L250E/L305/L305B	2" NPT	2" NPT

## 1.5 Oil Filling

The pump is shipped without oil. After level installation and correct rotation has been established, fill the pump with recommended motor oil through the oil fill port. Oil level should be at the 3/4 position on the oil sight glass.

Non-detergent oil should be used. Airtech recommends either ATO-1000 for normal duty operation or ATO-2000 and ATO-4000 for severe duty operation. **L21 must use ATO4000 oil only.** ATO oil is a high quality vacuum oil that will provide longer running time between oil changes, better lubrication at high operating temperatures and prolongs the life of the exhaust filter elements. Oil detergent additives can cause exhaust filters to become clogged and shorten their service life.

The following table gives the approximate quantities of oil required for each model.

OIL	
Pump Model	Capacity (Qt)
L12/L21	.5
L25/L40/L40B	1.0
L63/L100	2.0
L160/L230	7.0
L160C/L250D/L250E/L305B	7.0

**Do not add fill oil with pump running or through the inlet or exhaust ports! Do not overfill.**

## 2.0 OPERATION

### 2.1 Start-up

Check rotation of the motor as described in paragraph 1.3 ...Power Requirements.

Fill the pump with oil as described in paragraph 1.5 ...Oil Filling

Start the pump with the inlet closed. Run the pump for a few minutes and then shut down. Check the oil level again and make sure the oil level is between the  $\frac{3}{4}$  mark and full on the upper oil sight glass.

Add oil if necessary. Pump oil should only be added when the pump is off and circulating oil has sufficient time to return to the oil sump.

### 2.2 Stopping the Pump

To stop the pump, turn off the power. A built in anti-suck back valve will prevent oil from the oil reservoir being sucked back into the cylinder after the pump is shutdown.

**Do not utilize the anti-suck back valve as a check valve. Consult Airtech Inc. for proper check valves.**

### 2.3 Gas Ballast

L-Series pumps are equipped with a gas ballast. The gas ballast valve is located between the inlet port and the exhaust box. Its main function is to prevent water vapor from condensing in the pump that causes emulsification of the oil resulting in possible pump failure.

In applications involving a moderate quantity of water vapor, it is recommended to run the pump for 10 minutes at normal operating temperature, prior to going on process. The pump should also be operated off process for 10 minutes prior to shut down. A slight air bleed (purge) is recommended during these 10-minute cycles to prevent the vapor from condensing in the pump.

## 3.0 MAINTENANCE

L-Series vacuum pumps require very little maintenance. To ensure optimum performance, the following maintenance steps should be followed:

### 3.1 Pump Oil

#### 3.1.1 Oil Level

Under normal circumstances it should not be necessary to add oil between oil changes. A significant drop in oil level means there is either an oil leak, a defective exhaust filter or O-ring, or a leaking anti-suck back valve. If the pump is smoking excessively, the exhaust filter may be installed improperly.

It is normal for the oil to be foamy or lightly colored in an operating pump. This may be normal aeration of the oil. If the oil appears milky or dark colored, it is contaminated or burned and must be changed.

Check the oil level only when the pump is shut off. Replenish oil if it drops below the  $\frac{1}{4}$  mark of the top sight glass. Oil must be added through the oil fill port only.

**Caution: Do not add oil while the pump is running, since hot oil can escape from the oil fill port.**

#### 3.1.2 Oil Type and Quantity

See section 1.5 -Oil Filling -for details on oil type and quantity

### 3.1.3 Oil Change

When using ATO-1000 oil, it is recommended to change the oil every 500-750 operating hours.

When using ATO-2000 or ATO-4000 oil, it is recommended to change the oil every 750-1000 operating hours.

**L21 must use ATO4000 oil only.**

Oil change frequency is dependent upon the application and ambient temperature. It is recommended that the customer monitor the condition of the oil during this period.

### 3.1.4 Oil Spin-On Filter

Replace automotive-type spin on filter at every oil change.

Pump Model	Airtech Part No.
L25-L100	ATOF-51348
L160-L305B	ATOF-51452

### 3.2 Inline (Inlet) Filter

Check inline (inlet) filter on a weekly basis. The filter cartridge should be cleaned or replaced when dirty. Consult Airtech Inc. for replacement element information.

**Caution: Depending on the mounting position of the filter, be careful not to allow accumulated foreign material to fall in the pump suction inlet when removing the filter cartridge. Horizontal filter installation is recommended to prevent this.**

### 3.3 Exhaust Filter

Replace these filters every 9 to 18 months of operation or as necessary. The service life of these filters varies depending upon the application and frequency of oil change. It is necessary to change these filters only when they become clogged. Indications of clogged filters are smoke or oil mist coming from the exhaust of the pump, higher than normal motor current, and the exhaust pressure gauge reading of 3 psig or greater.

**Do not clean or re-use these filters. Filters must be disposed of in a proper way as they might contain toxic substances carried over from the process. Replace O-rings on filter when changing.**

### 3.4 Maintenance Chart

See the motor manufacturer's manual for the periodic motor maintenance.

**Daily:** visually check oil level and color.

**Weekly:** inspect inline (inlet) filter.

**Every 2-6 months:** drain and discard oil from pump while hot. Refill with fresh oil.

**Every 9-18 months:** replace exhaust filter elements and O-ring.

**The operating life of the pump is greatly enhanced based on the oil quality and condition of the filters. Periodic maintenance will ensure a reliable operating vacuum pump.**

### 3.5 Overhaul Kit and Accessories

An overhaul kit contains a set of gaskets, O-rings, vanes, bearing, bearing sleeves, shaft seals and taper pins. Please consult Airtech Inc. parts department for information.

## 4.0 PROBLEM SOLVING

### 4.1 Problem

Pump does not reach end pressure. This is the lower absolute (best vacuum) when running with the inlet closed.

#### 4.1.1 Possible Cause

Oil condition is most often the cause of not reaching end vacuum.

*Remedy:* drain oil from pump and refill with fresh oil. Run pump with fresh oil for 15 minutes then take new pressure reading.

#### 4.1.2 Possible Cause

Inlet screen clogged with debris.

*Remedy:* clean screen and check inlet filter element.

#### 4.1.3 Possible Cause

Shaft seal leak.

*Remedy:* replace shaft seal, from overhaul kit, or call Airtech for exchange program.

#### 4.1.4 Possible Cause

Vane stuck in rotor slot.

*Remedy:* drain oil with flushing oil. Run pump for 15 minutes and drain. Replace fluid with fresh oil, exhaust filter, and spin on filter. Replace vane from overhaul kit; call Airtech for exchange program

#### 4.1.5 Possible Cause

Anti-suck back valve stuck in closed position due to oil contamination.

*Remedy:* disassemble valve and screen, clean as required. Drain old oil and replace with fresh oil.

#### 4.1.6 Possible Cause

No oil or low oil level in reservoir.

*Remedy:* shut down pump, drain balance of oil and refill with fresh oil.

#### 4.1.7 Possible Cause

Vacuum fitting or hose is not leak tight.

*Remedy:* check hose and *pipe* connections for leaks.

#### 4.1.8 Possible Cause

Radial clearance between rotor and cylinder are no longer adequate.

*Remedy:* overhaul pump or call Airtech Inc. for exchange program.

## **4.2 Problem**

Pump runs very noisy.

### **4.2.1 Possible Cause**

Coupling insert is worn.

*Remedy:* replace coupling insert in motor/pump coupling.

### **4.2.2 Possible Cause**

Vanes stuck

*Remedy:* follow flush procedure from 4.1.4 or replace vane or call Airtech Inc. for exchange program.

### **4.2.3 Possible Cause**

Bearing noise

*Remedy:* replace bearings or call Airtech Inc. for exchange program.

## **4.3 Problem**

Pump starts, but labors and draws high amperage.

### **4.3.1 Possible Cause**

Oil is too viscous.

*Remedy:* drain and change with fresh oil.

### **4.3.2 Possible Cause**

Exhaust filter is clogged.

*Remedy:* replace exhaust filters, maintain proper oil condition, oil level and use ATO oil. -make sure inlet filter is operational preventing particulate carryover.

### **4.3.3 Possible Cause**

Loose connection in motor terminal box wired for wrong voltage.

*Remedy:* check wiring diagram for proper connections; tighten or replace loose connections.

### **4.3.4 Possible Cause**

Foreign particles in pump. Broken vanes or seized bearings.

*Remedy:* overhaul pump or call Airtech Inc. for exchange program.

### **4.3.5 Possible Cause**

Pump is overfilled with oil or wrong kind of oil is in pump.

*Remedy:* drain oil; use correct type of ATO oil.

### **4.3.6 Possible Cause**

Pump runs in wrong direction.

*Remedy:* check for correct rotation. If incorrect, switch any two leads.

## **4.4 Problem**

Pump will not start.

### **4.4.1 Possible Cause**

Supply voltage is not proper or is overloaded. Motor starter overload settings are too low or improper; fuses are burned; wire size is too small or too long causing a voltage drop.

*Remedy:* check voltage supply; overload settings in motor starter for size and settings according to motor nameplate. Install proper size wire. If ambient temperature is high, use the next larger size overloads or adjust settings 5% above motor nameplate value.

*Remedy:* turn pump fan by hand. If it will not turn, remove motor from pump and check motor and pump separately. Repair or replace if needed or call Airtech Inc. for exchange program.



#### **4.5 Problem**

Pump smokes at the exhaust side or expels oil droplets from the exhaust.

##### **4.5.1 Possible Cause**

-Exhaust filters are not properly installed with O-ring; Filter media is damaged.

*Remedy:* check exhaust filter placement and replace if needed.

##### **4.5.2 Possible Cause**

Exhaust filters are clogged with foreign particles.

*Remedy:* replace filter and O-ring.

##### **4.5.3 Possible Cause**

Oil is not recirculating properly.

*Remedy:* check oil quality and make certain oil lines are clean.

#### **4.6 Problem**

Pump is running too hot. (Typical operating temperature of the L-Series pumps is 120-200o Fahrenheit.)

##### **4.6.1 Possible Cause**

Not enough oil in the oil reservoir or oil is badly burned or carbonized.

*Remedy:* drain oil and refill with proper ATO oil; change oil more frequently.

##### **4.6.2 Possible Cause**

Not enough air ventilation to pump

*Remedy:* clean radiator and motor fins. Make certain a sufficient amount of fresh air is supplied to the pump.

#### **4.7 Problem**

Pump will not operate (seized up).

##### **4.7.1 Possible Cause**

Pump operated without oil and vanes broke

*Remedy:* Call Airtech Inc for exchange program

##### **4.7.2 Possible Cause**

Liquid carry over into pump cylinder broke vanes while pump was running.

*Remedy:* Install knock-out pot at inlet of pump

## 5.0 Motor and Electrical Data

	12	21	25	40	40B	63	100	160B	160C	230B	250D/ L250E	305/ 305B
<b>HP</b>	.75	1	1.5	2	2	3	5	5	7.5	7.5	10	12
<b>RPM</b>	1725	3450	1725	1725	1725	1725	1725	1725	1725	1725	1725	1725
<b>Full Load Amp</b>	2.6/1.3	3.2/1.6	5.3/5/2.5	6.5/6.2/3.1	6.5/6.2/3.1	9/8.6/4.3	14/13.4/6.7	14/13.4/6.7	22/20/10	22/20/10	28.5/28.4/14.2	30.9/17.9
<b>Voltage</b>	230/460	230/460	208/230/460	208/230/460	208/230/460	208/230/460	208/230/460	208/230/460	208/230/460	208/230/460	208/230/460	230/460

## 6.0 Technical Data

		12	21	25	40	40B	63	100	160B	160C	230B	250D/ L250E	305/ 305B
<b>Displacement</b>	<b>CFM</b>	7	15	21	32	28	45	70	112	130	155	180	212
<b>Guaranteed End Vacuum</b>	<b>TORR</b>	2	2	0.5	0.5	0.5	0.5	0.5	0.5	0.5	0.5	0.5	0.5
<b>Max Sound Level</b>	<b>dB</b>	59	62	67	67	67	70	70	72	74	74	74	76
<b>Motor Size</b>	<b>3PH</b>	.5	1	1.5	2	2	3	5	5	7.5	7.5	10	12
<b>Pump Rotation Speed</b>	<b>RPM</b>	1725	3600	1725	1725	1725	1725	1725	1725	1725	1725	1725	1725
<b>Oil Capacity</b>	<b>Qt.</b>	0.5	0.5	1	1	1	2	2	7	7	7	7	7
<b>Inlet Connection</b>	<b>NPT-(in.)</b>	1/2	1/2	1 1/4	1 1/4	1 1/4	1 1/4	1 1/4	2	2	2	2	2
<b>Weight</b>	<b>Lbs.</b>	42	42	108	116	116	175	185	306	390	377	407	415

# L12, L21

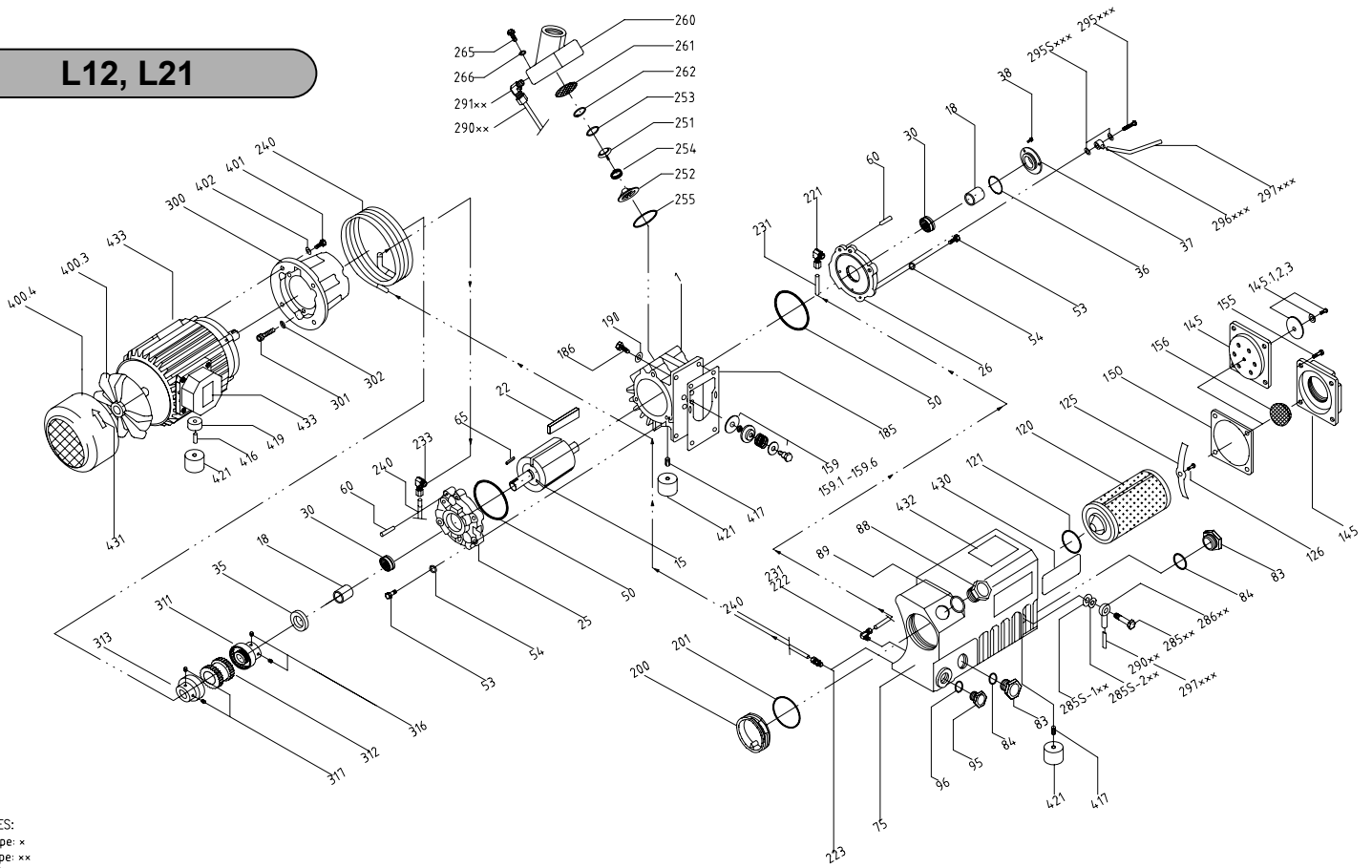

NOTES:  
 N Type: \*  
 L Type: \*\*  
 NM Type: \*\*\*

Pos. No.	Description	L12 Qty	L21 Qty	Pos. No.	Description	L12 Qty	L21 Qty	Pos. No.	Description	L12 Qty	L21 Qty
1	Cylinder	1	1	159-4	Exhaust valve plate	1	1	296***	Banjo fitting (For NM Only)	1	1
15	Rotor	1	1	159-5	Exhaust valve lock nut	1	1	297***	Oil Return tube (For NM Only)	1	1
18	Sleeve, Bearing	2	2	159-6	Exhaust valve seat plate	1	1	300	Motor mounting bracket	1	1
22	Vane	3	3	186	Allen bolt	4	4	301	Allen bolt	3	3
25	A-end plate	1	1	190	Spring lock washer	4	4	302	Spring lock washer	3	3
26	B-end plate	1	1	200	Plug, Drum	1	1				
30	Bearing	2	2	201	O-Ring, Drum plug	1	1				
35	Shaft seal	1	1	221	Elbow hydraulic fitting	1	1				
36	O-Ring, Bracket	1	1	222	Elbow hydraulic fitting	1	1				
37	Bracket	1	1	223	Straight hydraulic fitting	1	1	310	Coupling Set( 311 ~313)	1	1
38	Hexagon head screw	3	3	231	Oil tube(B)	1	1	311	Coupling, pump side	1	1
50	O-Ring, End plate	2	2	233	Elbow hydraulic fitting	1	1	312	Coupling, sleeve	1	1
53	Hexagon head screw	6	6	240	Cooling spiral	1	1	313	Coupling, Motor side	1	1
54	Spring lock washer	6	6	251	Check valve plate	1	1	316	Set screw (pump side)	2	2
60	Taper pin	4	4	252	Check valve guide	1	1	317	Set screw ( Motor side)	2	2
65	Shaft key	1	1	253	O-Ring, Check valve plate	1	1	400	Motor (IEC) for WOVP-0200	1	1
75	Oil sump	1	1	254	Check valve spring	1	1	400.3	Motor fan blade	1	1
83	Oil sight glass	1	1	255	O-Ring, Inlet part	1	1	400.4	Motor fan cover	1	1
84	Gasket, Oil sight glass	1	1	260	Inlet flange, NM type	1	1	401	Hexagon head screw	4	4
88	Plug, Oil fill	1	1	260	Inlet flange, L type	1	1	402	Spring lock washer	4	4
89	O-Ring, Oil fill plug	1	1	261	Inlet screen	1	1	416	Slotted set screw	1	1
95	Plug, Oil Drain	1	1	262	Retaining ring for bores	1	1	417	Slotted set screw	2	2
96	O-Ring, Oil drain plug	1	1	265	Hexagon head screw	4	4	419	Sleeve	1	1
120	Exhaust filter	1	1	266	Spring lock washer	4	4	421	Rubber foot	3	3
121	O-Ring, Exhaust filter	1	1	270*	Plug (For N only)	1	1	430	Name plate	1	1
125	Filter spring	1	1	275*	Oil return valve (For N only)	1	1	431	Directional arrow label	1	1
126	Slotted cheese head screw	1	1	275S*	Sealing ring (For N only) for 275*	1	1	490	Gasket Set	1	1
145	Exhaust cover (w/ threaded flange)	1	1	285**/****	Oil Recirculation Screw (For L or NM)	1	1	500	Maintenance Kit	1	1
150	Gasket, Exhaust cover	1	1	286**/****	Banjo fitting (For L or NM )	1	1	510	Conversion kit, L type	1	1
155	Allen bolt	4	4	285S-1**	Sealing ring (For L or NM) for 285**	1	2	530	Conversion kit, NM Type	1	1
156	Outlet screen	1	1	285S-2**	Sealing ring (For L or NM) for 285**	2	2	145-1	Rubber Flap for 02145	1	1
159	Exhaust valve ass'y( 159.1~ 159.6)	1	1	290**	Oil return tube (For L only)	1	1	145-2	Washer for 02145	1	1
159-1	Exhaust valve fixed bolt	1	1	291**	Elbow hydraulic fitting ( For L only)	1	1	145-3	Slotted cheese head screw for 02145	1	1
159-2	Exhaust valve washer	1	1	295S***	Sealing ring (For NM) for 295**	2	2	800	Inlet Air Filter	1	1
159-3	Exhaust valve spring	1	1	295***	Oil return valve (For NM Only)	1	1	900	Pump Module	1	1

# L25, L40

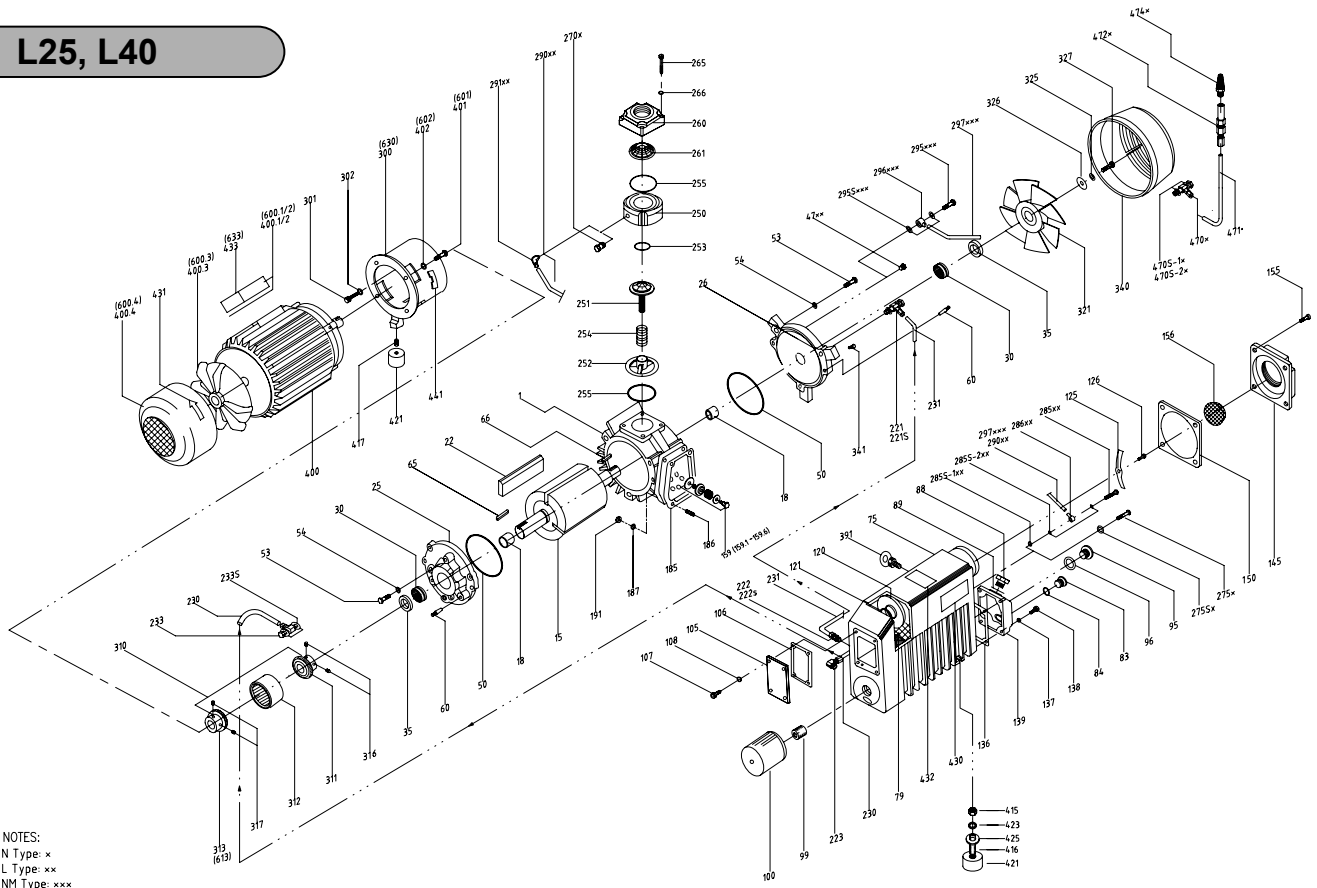

NOTES:  
 N Type: x  
 L Type: xx  
 NM Type: xxx

Pos. No.	Description	L25 Qty	L40 Qty	Pos. No.	Description	L25 Qty	L40 Qty	Pos. No.	Description	L25 Qty	L40 Qty
1	Cylinder	1	1	159-4	Exhaust valve plate	2	2	313A	Coupling, Motor side	1	1
15	Rotor	1	1	159-5	Exhaust valve lock nut	2	2	316	Set screw (pump side)	2	2
18	Sleeve, Bearing	2	2	159-6	Exhaust valve seat plate	2	2	317	Set screw (Motor side)	2	2
22	Vane	3	3	185	Gasket, Cylinder	1	1	321	Fan, Pump shaft end	1	1
25	A-end plate	1	1	186	Stud	4	4	325	Washer, Spring lock	1	1
26	B-end plate	1	1	187	Spring lock washer	4	4	326	Washer, plain	1	1
30	Bearing	2	2	191	Hexagon nut	1	4	327	Hexagon head screw	1	1
35	Shaft seal	2	2	221	BSLM hydraulic fitting	1	1	340	Fan hood	1	1
42	Supporting ring	2	2	221S	Sealing Ring for 221	2	2	341	Hexagon head screw	3	3
43	Hexagon head screw	4	4	222	Straight hydraulic fitting	1	1	391	Eye bolt	1	1
47	Plug	1	1	233	BSLM hydraulic fitting	1	1	400	Motor (IEC)-50Hz	1	1
50	O-Ring, End plate	2	2	230	Oil tube(A)	1	1	400	Motor (IEC)-60Hz	1	1
53	Hexagon head screw	6	6	231	Oil tube(B)	1	1	400.3	Motor Fan (IEC)	1	1
54	Spring lock washer	6	6	233	BSLM hydraulic fitting	1	1	400.4	Motor Fan Cover (IEC)	1	1
60	Taper pin	4	4	233S	Sealing ring for 233	2	2	401	Hexagon head screw	4	4
63	Plug	1	1	251	Check valve plate	1	1	402	Spring lock washer	4	4
65	A-Shaft key	1	1	252	Check valve guide	1	1	415	Hexagon nut	1	1
66	B-Shaft key	1	1	253	O-Ring, Check valve plate	1	1	416	Slotted set screw	1	1
75	Oil sump	1	1	254	Check valve spring	1	1	417	Slotted set screw	2	2
79	Sheet metal baffle	1	1	250	Inlet flange, lower housing	1	1	421	Rubber foot	3	3
83	Oil sight glass	1	1	255	O-Ring, Inlet part	2	2	423	Spring lock washer	1	1
84	Gasket, Oil sight glass	1	1	260	Inlet flange, upper housing	1	1	425	Washer	1	1
88	Plug, Oil fill	1	1	261	Inlet screen	1	1	430	Name plate	1	1
89	O-Ring, Oil fill plug	1	1	265	Allen bolt	4	4	431	Directional arrow label	1	1
95	Plug, Oil drain	1	1	266	Spring lock washer	4	4	470	BSLM hydraulic fitting	1	1
96	O-Ring, Oil drain plug	1	1	270*	Plug (For N Onry)	1	1	470S-1	Sealing ring for 470	1	1
99	Threaded fitting	1	1	275*	Oil return valve (For N only)	1	1	470S-2	Sealing ring for 470	1	1
100	Oil filter	1	1	275S*	Sealing ring (For N only) for 275*	1	1	471	Oil tube	1	1
105	Oil sump cover plate	1	1	285**/****	Oil Recirculation Screw (For L or NM)	1	1	472	Non return valve	1	1
106	Gasket, Oil sump cover	1	1	286**/****	Banjo fitting (For L or NM )	1	1	474	Air filter	1	1
107	Allen bolt	4	6	285S-1**	Sealing ring (For L or NM) for 285**	1	1	480	Gas Ballast Kit	1	1
108	Sealing ring	4	4	285S-2**	Sealing ring (For L or NM) for 285**	3	3	490	Gasket Set	1	1
120	Exhaust filter (NEW)	1	1	290**	Oil return tube (For L only)	1	1	500	Maintenance Kit	1	1
120	Exhaust filter (OLD)	1	1	291**	Elbow hydraulic fitting (For L only)	1	1	510	Conversion kit, L Type	1	1
121	O-Ring, Exhaust filter	1	1	295S***	Sealing ring (For NM) for 295**	2	2	520	Conversion kit, N Type	1	1
125	Filter spring	1	1	295***	Oil return valve (For NM only)	1	1	530	Conversion kit, NM Type	1	1
126	Slotted cheese head screw	1	1	296***	Banjo fitting (For NM only)	1	1	600	Motor(NEMA)	1	1
136	Gasket, Service cover	1	1	297***	Oil Return tube (For NM only)	1	1	600.3	Motor Fan(NEMA)	1	1
137	Sealing ring	4	4	300	Motor mounting bracket (IEC)	1	1	600.4	Motor Fan Cover(NEMA)	1	1
138	Allen bolt	4	4	301	Allen bolt	3	3	601	Hexagon head screw(NEMA)	1	1
139	Service cover	1	1	223	Elbow hydraulic fitting	1	1	602	Spring lock washer(NEMA)	4	4
145	Exhaust cover (w/ threaded flange)	1	1	302	Spring lock washer	3	3	612A	Coupling set (313A+312C=613),nema	1	1
150	Gasket, Exhaust cover	1	1	310	Coupling Set( 311 ~313), 1Ph	1	1	613	Coupling, Motor side(NEMA)	1	1
155	Allen bolt	4	4	311	Coupling, pump side	1	1	630	Motor Mounting Bracket(NEMA)	1	1
156	Outlet screen	1	1	312	Coupling insert	1	1				
159	Exhaust valve ass'y (159.1~159.6)	2	2	313	Coupling, Motor side	1	1				
159-1	Exhaust valve fixed bolt	2	2	310A	Coupling Set( 311 ~313), 3Ph	1	1				
159-2	Exhaust valvewasher	2	2	311A	Coupling, pump side	1	1	800	Inlet Air Filter	1	1
159-3	Exhaust valve spring	2	2	312A	Coupling, sleeve	1	0	900	Pump Module	1	1

# L40B

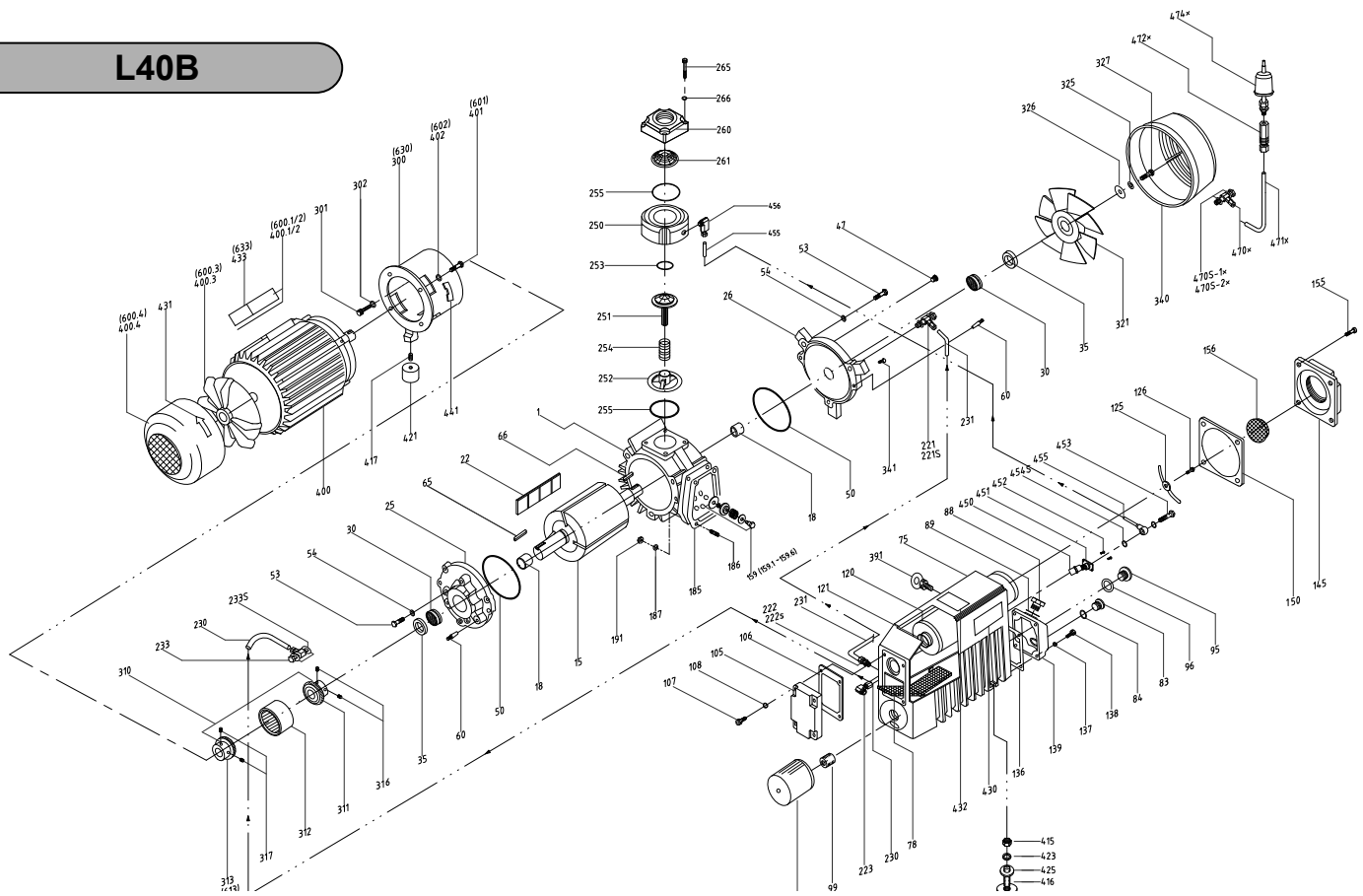

Pos. No.	Description	L40B Qty	Pos. No.	Description	L40B Qty	Pos. No.	Description	L40B Qty
1	Cylinder	1	159-6	Exhaust valve seat plate	2	415	Hexagon nut	1
15	Rotor	1	185	Gasket, Cylinder	1	416	Slotted set screw	1
18	Sleeve, Bearing	2	186	Stud	4	417	Slotted set screw	2
22	Vane	3	187	Spring lock washer	4	421	Rubber foot	3
25	A-end plate	1	191	Hexagon nut	4	423	Spring lock washer	1
26	B-end plate	1	221	BSLM hydraulic fitting	1	425	Washer	1
30	Bearing	2	221S	Sealing Ring for 221	2	430	Name plate	1
35	Shaft seal	2	222	Straight hydraulic fitting	1	441	Protection cover	1
42	Supporting ring	2	223	Elbow hydraulic fitting	1	450	Float	1
43	Hexagon head screw	4	233	BSLM hydraulic fitting	1	451	Nozzle Assembly	1
47	Plug	1	230	Oil tube(A)	1	451.1	O-Ring for Nozzle assy	1
50	O-Ring, End plate	2	231	Oil tube(B)	1	452	Bolt	1
53	Hexagon head screw	6	233S	Sealing ring for 233	2	453	Bolt for Banjo Fitting, oil return	1
54	Spring lock washer	6	251	Check valve plate	1	454S	Sealing ring for 454	1
60	Taper pin	4	252	Check valve guide	1	455	Oil Return tube with Banjo fitting	1
63	Plug	1	253	O-Ring, Check valve plate	1	456	Elbow hydraulic fitting	1
65	A-Shaft key	1	254	Check valve spring	1	431	Directional arrow label	1
66	B-Shaft key	1	250	Inlet flange, lower housing	1	470	BSLM hydraulic fitting	1
75	Oil sump	1	255	O-Ring, Inlet part	2	470S-1	Sealing ring for 470	1
78	Steel demister	1	260	Inlet flange, upper housing	1	470S-2	Sealing ring for 470	1
83	Oil sight glass	1	261	Inlet screen	1	471	Oil tube	1
84	Gasket, Oil sight glass	1	265	Allen bolt	4	472	Non-return valve	1
88	Plug, Oil fill	1	266	Spring lock washer	4	474	Air filter With Fitting	1
89	O-Ring, Oil fill plug	1	270*	Plug (For N Only)	1	480	Gas Ballast Kit	1
95	Plug, Oil drain	1	300	Motor mounting bracket (IEC)	1	490	Gasket Set	1
96	O-Ring, Oil drain plug	1	301	Allen bolt	3	500	Maintenance Kit	1
99	Threaded fitting	1	302	Spring lock washer	3	520	Conversion kit, N Type	1
100	Oil filter	1	310	Coupling Set( 311 ~313), 1Ph	1	600	Motor(NEMA)	1
105	Oil sump cover plate	1	311	Coupling, pump side	1	600.3	Motor Fan(NEMA)	1
106	Gasket, Oil sump cover	1	312	Coupling insert	1	600.4	Motor Fan Cover(NEMA)	1
107	Allen bolt	6	313	Coupling, Motor side	1	601	Hexagon head screw(NEMA)	1
108	Sealing ring	4	310A	Coupling Set( 311 ~313), 3Ph	1	602	Spring lock washer(NEMA)	4
120	Exhaust filter (NEW)	1	311A	Coupling, pump side	1	612A	Coupling set (313A+312C=613),nema	1
120	Exhaust filter (OLD)	1	312A	Coupling, sleeve	1	613	Coupling, Motor side(NEMA)	1
121	O-Ring, Exhaust filter	1	313A	Coupling, Motor side	1	630	Motor Mounting Bracket(NEMA)	1
125	Filter spring	1	316	Set screw (pump side)	2	613	Coupling, Motor side(NEMA)	1
126	Slotted cheese head screw	1	317	Set screw ( Motor side)	2	630	Motor Mounting Bracket(NEMA)	1
136	Gasket, Service cover	1	321	Fan, Pump shaft end	1			
137	Sealing ring	4	325	Washer, Spring lock	1			
138	Allen bolt	4	326	Washer, plain	1			
139	Service cover	1	327	Hexagon head screw	1			
145	Exhaust cover (w/ threaded flange)	1	328	Fan Kit, (# 321, 325, 326, 327, 66)	1			
150	Gasket, Exhaust cover	1	340	Fan hood	1			
155	Allen bolt	4	341	Hexagon head screw	3			
156	Outlet screen	1	391	Eye bolt	1			
159	Exhaust valve ass'y (159.1~159.6)	2	400	Motor (IEC)-50Hz	1			
159-1	Exhaust valve fixed bolt	2	400	Motor (IEC)-60Hz	1			
159-2	Exhaust valvewasher	2	400.3	Motor Fan (IEC)	1			
159-3	Exhaust valve spring	2	400.4	Motor Fan Cover (IEC)	1			
159-4	Exhaust valve plate	2	401	Hexagon head screw	4	800	Inlet Air Filter	1
159-5	Exhaust valve lock nut	2	402	Spring lock washer	4	900	Pump Module	1

# L63, L100

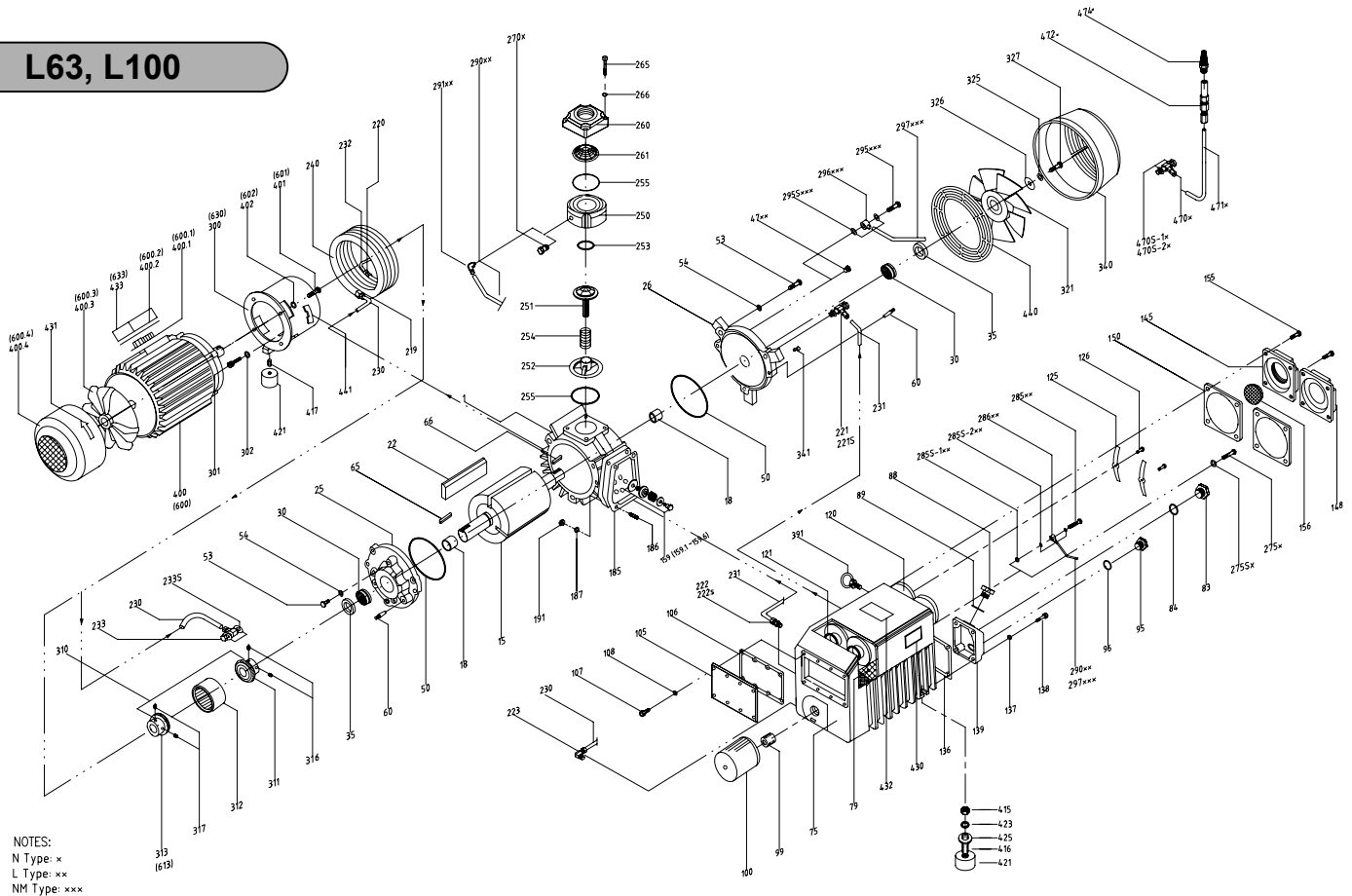

Pos. No.	Description	L63 Qty	L100 Qty	Pos. No.	Description	L63 Qty	L100 Qty	Pos. No.	Description	L63 Qty	L100 Qty
1	Cylinder	1	1	159.2	Exhaust valve washer	2	2	311A	Coupling, pump side	1	1
15	Rotor	1	1	159.3	Exhaust valve spring	2	2	312A	Coupling, sleeve	1	1
18	Sleeve, Bearing	2	2	159.4	Exhaust valve plate	2	2	313A	Coupling, Motor side	1	1
22	Vane	3	3	159.5	Exhaust valve lock nut	2	2	316	Set screw (pump side)	2	2
25	A-end plate	1	1	159.6	Exhaust valve seat plate	2	2	317	Set screw ( Motor side)	2	2
26	B-end plate	1	1	185	Gasket, Cylinder	1	1	321	Fan, Pump shaft end	1	1
30	Bearing	2	2	186	Stud	4	4	325	Washer, Spring lock	1	1
35	Shaft seal	2	2	187	Spring lock washer	4	4	326	Washer, plain	1	1
42	Supporting ring	2	2	191	Hexagon nut	4	4	327	Hexagon bolt	1	1
43	Hexagon head screw	4	4	219	St hydraulic fit. WOVP-200 Only	0	1	340	Fan hood	1	1
47	Plug	1	1	220	St hydraulic fit. WOVP-200 only	0	1	341	Hexagon head screw	3	3
50	O-Ring, End plate	2	2	221	BSLM hydraulic fitting	1	1	391	Eye bolt	1	1
53	Hexagon head screw	6	6	221S	Sealing Ring for 221	2	2	400	Motor (IEC)-50Hz	1	1
54	Spring lock washer	6	6	222	Straight hydraulic fitting	1	1	400	Motor (IEC)-60	1	1
60	Taper pin	4	4	223	Elbow hydraulic fitting	1	0	400.3	Motor Fan (IEC)	1	0
63	Plug	1	1	230	Oil tube(A)	1	1	400.4	Motor Fan Cover (IEC)	1	0
65	A-Shaft key	1	1	231	Oil tube(B)	1	1	401	Hexagon head screw	4	4
66	B-Shaft key	1	1	232	A-Oil tubing (B) (WOVP-200 Only)	0	1	402	Spring lock washer	4	4
75	Oil Sump	1	1	233	BSLM hydraulic fitting	1	1	415	Hexagon nut	1	1
78	Steel demister	1	1	233S	Sealing Ring for 233	2	2	416	Slotted set screw	1	1
79	Sheet metal baffle	1	1	240	Cooling Coil (WOVP-200 Only)+(219+220)	0	1	417	Slotted set screw	2	2
83	Oil sight glass	1	1	250	Inlet flange, lower housing	1	1	421	Rubber foot	3	3
84	Gasket, Oil sight glass	1	1	251	Check valve plate	1	1	423	Spring lock washer	1	1
88	Plug, Oil fill	1	1	252	Check valve guide	1	1	425	Washer	1	1
89	O-Ring, Oil fill plug	1	1	253	O-Ring, Check valve plate	1	1	430	Name plate	1	1
95	Plug, Oil drain	1	1	254	Check valve spring	1	1	431	Directional arrow label	1	1
96	O-Ring, Oil drain plug	1	1	255	O-Ring, Inlet part	2	2	470*	BSLM hydraulic fitting	1	1
99	Theaded fitting	1	1	260	Inlet flange, upper housing	1	1	470S*-1	Sealing ring for 470	1	1
100	Oil filter	1	1	261	Inlet screen	1	1	470S*-2	Sealing ring for 470	1	1
105	Oil sump cover plate	1	1	265	Allen bolt	4	4	471*	Oil Tube(C)	1	1
106	Gasket, Oil sump cover	1	1	266	Spring lock washer	4	4	472*	Gas Ballast(Non return valve)	1	1
107	Allen bolt	8	8	270*	Plug (For N only)	1	1	474*	Air filter	1	1
108	Sealing ring	8	8	275*	Oil return valve (For N only)	1	1	480*	Gas Ballast Kit ( 470*~474*)	1	1
120	Exhaust filter	2	2	275S*	Sealing ring (For N only) for 275*	1	1	490	Gasket Kit	1	1
121	O-Ring, Exhaust filter	2	2	285**/***	Oil Recirculation Screw (For L or NM)	1	1	500	Maintenance Kit	1	1
125	Filter spring	2	2	286**/***	Banjo fitting (For L or NM )	1	1	510	Conversion kit, L type	1	1
126	Slotted cheese head screw	2	2	285S-1*	Sealing ring (For L or NM) for 285**	1	1	520	Conversion kit, N type	1	1
136	Gasket, Service cover	1	1	285S-2*	Sealing ring (For L or NM) for 285**	3	3	530	Conversion kit, NM type	1	1
137	Sealing ring	4	4	290**	Oil return tube (For L only)	1	1	600	Motor(NEMA)	1	1
138	Allen bolt	4	4	291**	Elbow hydraulic fitting ( For L only)	1	1	600.3	Motor Fan(NEMA)	1	1
139	Service cover	1	1	295S***	Sealing ring (For NM) for 295**	2	2	600.4	Motor Fan Cover(NEMA)	1	1
145	Exhaust cover ( threaded flange)	1	1	295***	Oil return valve (For NM only)	1	1	601	Hexagon head screw(NEMA)	4	4
148	Exhaust cover (Blocked)	1	1	296***	Banjo fitting (For NM only)	1	1	602	Spring lock washer(NEMA)	4	4
150	Gasket, Exhaust cover	2	2	297***	Oil Return tube (For NM only)	1	1	612A	Coupling Set(311A+312C+613),NEMA	1	1
155	Allen bolt	8	8	300	Motor mounting bracket (IEC)	1	1	613A	Coupling, Motor side(NEMA)	1	1
156	Outlet screen	1	1	301	Allen bolt	3	3	630	Motor Mounting Bracket(NEMA)	1	1
159	Exhaust valve ass'y( 159.1~ 159.6)	2	2	302	Spring lock washer	3	3	800	Inlet Air Filter	1	1
159.1	Exhaust valve fixed bolt	2	2	310A	Coupling Set( 311 ~313)	1	1	900	Pump Module	1	1

# L160, L230

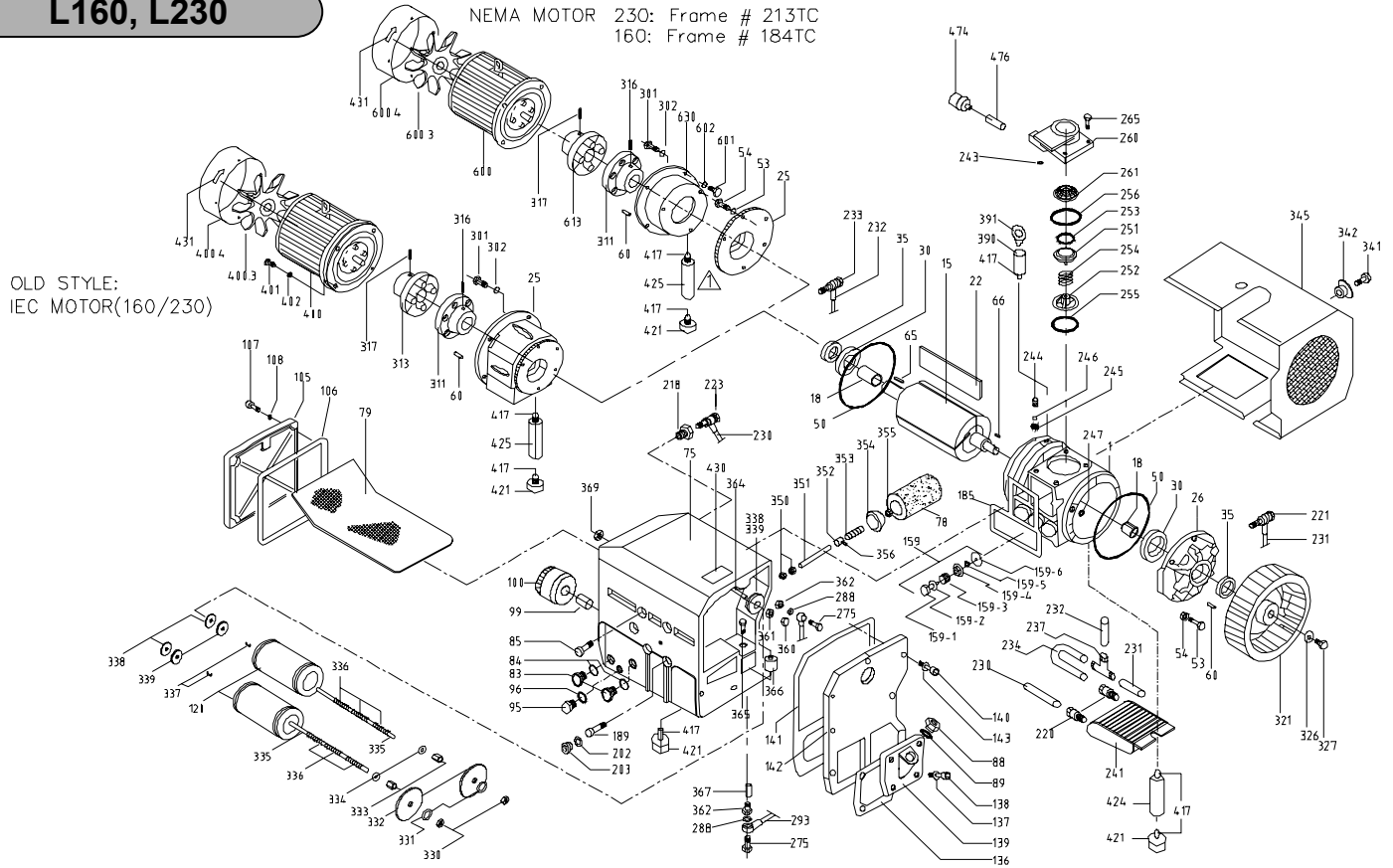

Pos. No.	L160, L230	Pos. No.	L160, L230	Pos. No.	L160, L230	Pos. No.	L160, L230
1	Cylinder	159	Exhaust valve ass'y	317	Set screw	425	Rubber foot support
15	Rotor	159-1	Exhaust valve fixed bolt	321	Pump shaft end fan	430	Name plate
18	Bearing sleeve	159-2	Exhaust valve washer	326	Washer	431	Directional Arrow
22	Vane	159-3	Exhaust valve spring	327	Hexagon head screw	474	Air filter
25	A-end plate, motor side	159-4	Exhaust valve plate	330	Hexagon nut	476	Ball valve
25	A-end plate	159-5	Exhaust valve lock nut	331	Washer	490	Gasket Kit
26	B-end plate	159-6	Exhaust valve seat plate	332	Exhaust filter cover	500	Maintenance Kit
30	Bearing	185	Cylinder gasket	333	Hexagon nut	600	Motor(NEMA)
35	Shaft seal	189	Allen bolt	334	Washer	600.3	Motor Fan(NEMA)
46	Sealing ring	202	O- ring	335	Separator valve stud	600.4	Motor Fan Cover(NEMA)
50	End plate o-ring	203	Locking screw	336	Separator valve spring	601	Hexagon head screw(NEMA)
53	Allen bolt	218	Socket	337	Flat spring	602	Spring lock washer(NEMA)
54	Spring Lock washer	230	Oil tube(A)	338	Separator valve flat-ring	613	Coupling, Motor side(NEMA)
60	Taper pin	231	Oil tube(B)	339	Separator valve support	630	Motor Mounting Bracket(NEMA)
65	A-shaft key	243	Gas ballast o-ring	340	Fan food		
66	B-shaft key	244	Ball guide	341	Allen bolt		
75	Oil sump	245	Ball	342	Cover holder		
78	Seal demister	246	Ball guide o-ring	350	Hexagon nut		
79	Steel metal baffle	247	End plate o-ring for gas ballast	351	Stud		
83	Oil sight glass,convex	251	Check valve plate	352	Adjusting ring		
84	Oil sight glass,gasket	252	Check valve guide	353	Deminster spring		
85	Allen bolt	253	Check valve plate flat-ring	354	Demister cover		
88	Oil fill plug	254	Check valve spring	355	Hexagon nut		
89	Oil fill plug o-ring	255	Inlet part o-ring	356	Set screw		
95	Oil drain plug	256	Hexagon nut	360	Hexagon nut		
96	Oil drain plug o-ring	257	Check valve plate stud	361	Washer		
99	Threaded fitting	258	Distance bushing	362	Connecting bolt		
100	Oil filter	259	O- ring	365	Hexagon head screw		
105	Oil sump cover	260	Inlet flange	366	Float		
106	Oil sump cover gasket	261	Inlet screen	367	Float valve nozzle		
107	Allen bolt	265	Allen bolt	369	Hexagon nut		
108	Sealing ring	275	Hollow-core screw	390	Adapter for eye bolt		
120	Exhaust filter	283	Hollow-core screw	391	Eye bolt		
136	Service cover gasket	285	Hollow-core screw	400	Motor		
137	Sealing ring	288	Sealing ring	400.3	Motor Fan		
138	Allen bolt	300	Motor Mounting Bracket (IEC)	400.4	Motor Fan Cover		
139	Service cover	301	Allen bolt	401	Hexagon head screw		
140	Allen bolt	302	Spring lock washer	402	Spring lock washer		
141	Separator cover gasket	311	Coupling, pump side	417	Slotted set screw		
142	Separator cover plate	313	Coupling, Motor side	421	Rubber foot		
143	Sealing ring	316	Set screw	424	Rubber foot support		

# L160B, L230B

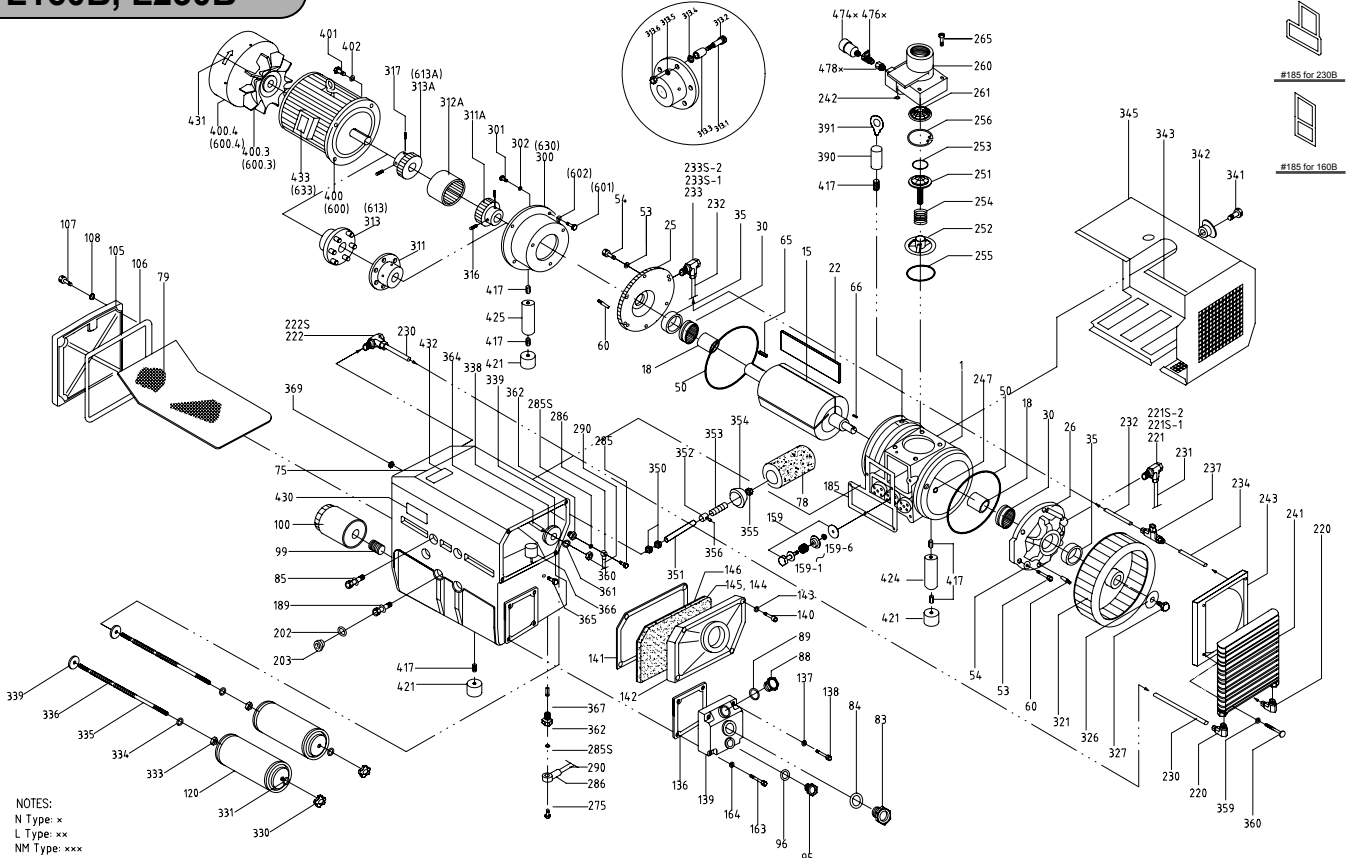

Pos. No.	Description	L160B Qty	L230B Qty	Pos. No.	Description	L160B Qty	L230B Qty	Pos. No.	Description	L160B Qty	L230B Qty	Pos. No.	Description	L160B Qty	L230B Qty
1	Cylinder	1	1	159	Exhaust valve ass'y( 159.1~ 159.6)	2	3	260	Inlet flange	1	1	362	Connecting bolt	2	2
15	Rotor	1	1	159.1	Exhaust valve fixed bolt	2	3	261	Inlet screen	1	1	364	Separator locking valve stud	1	0
18	Sleeve, Bearing	2	2	159.2	Exhaust valve washer	2	3	265	Allen bolt	4	4	365	Hexagon head screw	2	2
22	Vane	3	3	159.3	Exhaust valve spring	2	3	275	Hollow-core screw	2	2	366	Float with rod	1	1
25	A-end plate, motor side	1	1	159.4	Exhaust valve plate	2	3	275S	Sealing ring	2	2	367	Float valve nozzle	1	1
26	B-end plate, Fan side	1	1	159.5	Exhaust valve lock nut	2	3	300	Motor Mounting Bracket (IEC)	1	1	369	Hexagon nut	2	2
30	Bearing	2	2	159.6	Exhaust valve seat plate	2	3	301	Allen bolt	3	3	390	Adapter for eye bolt	1	1
35	Shaft seal	2	2	185	Gasket, Cylinder	1	1	302	Spring lock washer	3	3	391	Eye bolt	1	1
50	O-Ring, End plate	2	2	189	Allen bolt	2	3	310	Coupling set( 310 ~313)	1	1	400	Motor (IEC)-50Hz	1	1
53	Allen bolt	12	12	202	O- ring	5	5	311	Coupling Half, Pump Side	1	1	400	Motor (IEC)-60Hz	1	1
54	Spring Lock washer	12	12	203	Locking screw	5	5	312	Connection bolt w/ rubber boot	6	6	400.3	Motor Fan (IEC)	1	1
60	Taper pin	4	4	218	Socket	1	1	313	Coupling Half, Motor Side	1	1	400.4	Motor Fan Cover (IEC)	1	1
65	A-shaft key	1	1	220	BMC Hydraulic Fitting	2	2	316	Set screw (Pump side)	2	2	401	Hexagon head screw	4	4
66	B-shaft key	1	1	221	BSLM Hydraulic fitting	1	1	317	Set screw (Motor side)	2	2	402	Spring lock washer	4	4
75	Oil sump	1	1	221S-1	Sealing Ring for 221	1	1	321	Fan, Pump shaft end	1	1	417	Slotted set screw	6	6
78	Steel demister	1	1	221S-2	Sealing Ring for 221	1	1	326	Washer	1	1	421	Rubber foot	3	3
79	Steel metal baffle	1	1	223	BSLM Hydraulic fitting	1	1	327	Hexagon head screw	1	1	424	Rubber foot support	1	1
83	Oil sight glass	2	2	223S-1	Sealing Ring for 223	1	1	330	Hexagon nut	1	2	425	Rubber foot support	1	1
84	Gasket, Oil sight glass	2	2	223S-2	Sealing Ring for 223	1	1	331	Washer	1	2	430	Name plate	1	1
85	Allen bolt	2	2	230	Oil tube (A-1)	1	1	332	Exhaust filter cover	1	2	431	Directional Arrow	1	1
88	Pulg, Oil fill	1	1	231	Oil tube (B-1)	1	1	333	Hexagon nut	1	2	474	Air filter	1	1
89	O-Ring, Oil fill plug	1	1	232	Oil Tube (B-2)	1	1	334	Washer	1	2	476*	Ball valve for N only	1	1
95	Plug, Oil drain	1	1	233	BSLM Hydraulic fitting	1	1	335	Separator valve stud	1	2	490	Gasket Kit	1	1
96	O-Ring, Oil drain plug	1	1	233S-1	Sealing Ring for 233	1	1	336	Separator valve spring	3	6	500	Maintenance Kit	1	1
99	Threaded fitting	1	1	233S-2	Sealing Ring for 233	1	1	337	Flat spring	1	2	510	Conversion kit, L type	1	1
100	Oil filter	1	1	234	Oil Tube(A-2)	1	1	338	Separator valve flat-ring	2	2	520	Conversion kit, N Type	1	1
105	Oil sump cover	1	1	237	BLT, Hydraulic Fitting	1	1	339	Separator valve support	2	2	600	Motor(NEMA)	1	1
106	Gasket, Oil sump cover	1	1	241	Radiator	1	1	341	Allen bolt	1	1	600.3	Motor Fan(NEMA)	1	1
107	Allen bolt	8	8	243	O-Ring, Gas ballast	1	1	342	Cover holder	1	1	600.4	Motor Fan Cover(NEMA)	1	1
108	Sealing ring for 107	8	8	244	Ball guide	1	1	345	Fan Hood	1	1	601	Hexagon head screw(NEMA)	4	4
120	Exhaust filter	1	2	245	Ball	1	1	350	Hexagon nut	1	2	602	Spring lock washer(NEMA)	4	4
136	Gasket, Service cover	1	1	246	O-Ring, Ball guide	1	1	351	Stud	1	1	613	Coupling, Motor side (NEMA)	1	1
137	Sealing ring	4	4	247	O-Ring, End plate for gas ballast	1	1	352	Adjusting ring	1	1	630A	Motor Mounting Bracket (NEMA)	1	1
138	Allen bolt	4	4	251	Check valve plate	1	1	353	Demister spring	1	1	630	Motor Mounting Bracket (NEMA)	1	1
139	Service cover	1	1	252	Check valve guide	1	1	354	Demister cover	1	1	800	Inlet Air Filter	1	1
140	Allen bolt	8	8	253	O-Ring, Check valve plate	1	1	355	Hexagon nut	2	2	900	Pump Module	1	1
141	Gasket, Separator cover	1	1	254	Check valve spring	1	1	356	Set screw	1	1				
142	Separator cover plate	1	1	255	O-Ring, Inlet part	1	1	360	Hexagon nut	1	1				
143	Sealing ring	8	8	256	Snap Ring	1	1	361	Washer	1	1				



# L160C

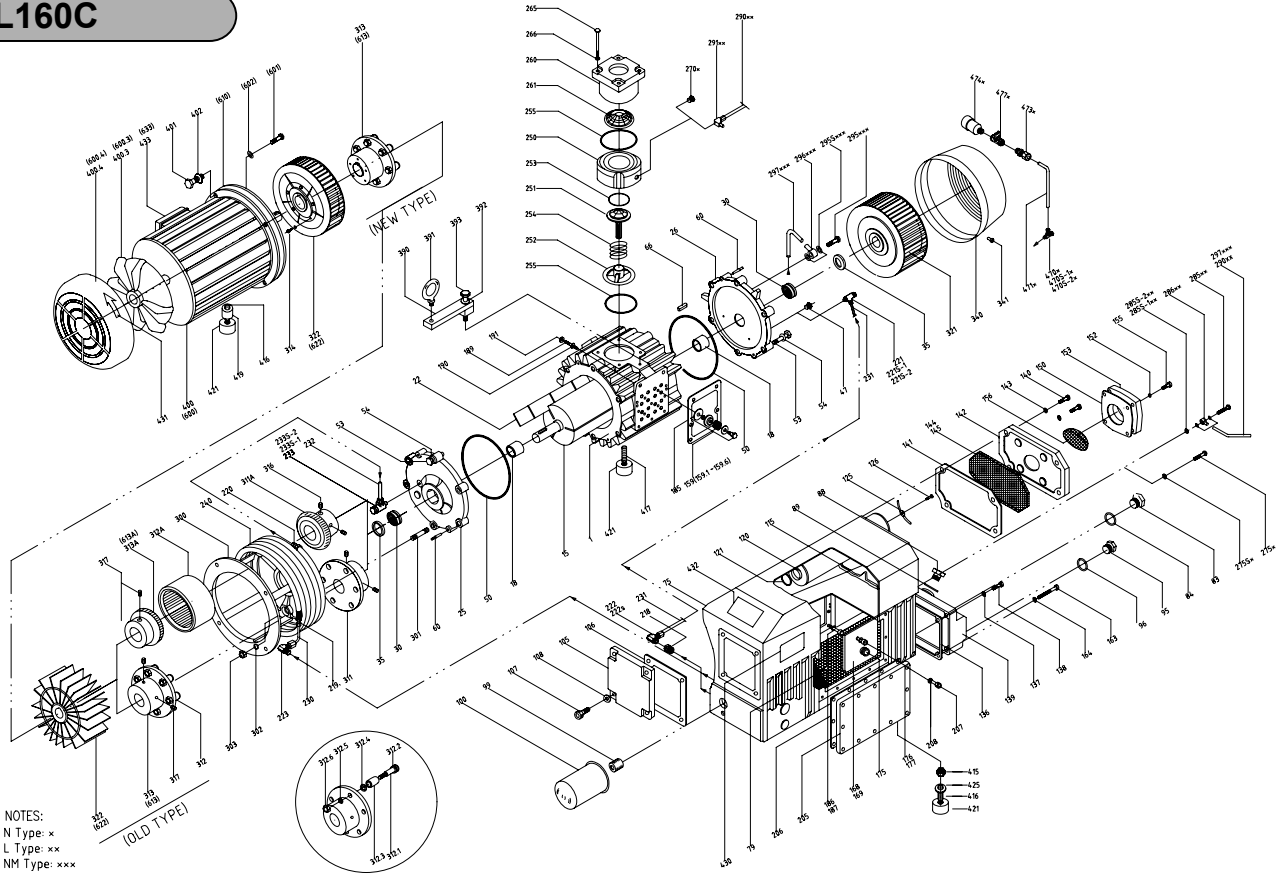

NOTES:  
 N Type: x  
 L Type: xx  
 NM Type: xxx

Pos. No.	Description	L160C Qty	Pos. No.	Description	L160C Qty	Pos. No.	Description	L160C Qty	Pos. No.	Description	L160C Qty
1	Cylinder	1	145	Starliner, baffle	1	233S-2	Sealing Ring for 233	1	391	Eye bolt	1
15	Rotor	1	150	Gasket, Exhaust cover	1	240	Cooling spiral	1	392	Spring Lock washer	1
18-1	Sleeve, Bearing	2	152	Sealing ring	4	250	Inlet flange Lower housing	1	393	Hexagon head screw	1
18-2	Sleeve, Bearing	2	153	Exhaust threaded cover	1	251	Check valve plate	1	400	Motor (IEC) 50Hz	1
22	Vane	3	155	Allen bolt	4	252	Check valve guide	1	400	Motor (IEC) 60 Hz	1
25	A-End plate	1	156	Outlet screen	1	253	O-Ring, Check valve plate	1	400.3	Motor Fan (IEC)	1
26	B-End plate	1	159	Exhaust valve ass'y (159.1~ 159.6)	4	254	Check valve spring	1	400.4	Motor Fan Cover (IEC)	1
30	Bearing	2	159-1	Exhaust valve fixed bolt	4	255	O-Ring, In-let part	2	401	Hexagon head screw	4
35	Shaft seal	2	159-2	Exhaust valve washer	4	260	Inlet flange, Upper housing	1	402	Spring Lock washer	4
42	Supporting ring	2	159-3	Exhaust valve spring	4	261	Inlet screen (conical)	1	415	Hex nut	1
43	Hexagon head screw	4	159-4	Exhaust valve plate	4	265	Allen bolt	4	416	Slotted set screw	2
47	Plug	1	159-5	Exhaust valve lock nut	4	266	Spring Lock washer	4	417	Slotted set screw	2
50	O-Ring, End plate	2	159-6	Exhaust valve seat plate	4	270*	Plug (N only)	1	419	Sleeve	1
53	Hexagon head screw	9	163	Allen bolt	2	275*	Oil return valve (N only)	1	421	Rubber foot	3
54	Spring Lock washer	9	164	Sealing ring	2	275S*(276)	Sealing ring (N only) for 275*	1	423	Spring Lock Washer	1
60	Taper Pin	4	168	O-Ring, Valve cover plate	1	285**/***	Oil Recirculation Screw (L / NM)	1	425	Washer	1
65	A-Shaft key	1	169	Valve cover plate	1	286**/***	BSLM Hyd. Fitting (L / NM)	1	430	Name plate	1
66	B-Shaft key	1	175	Plug	1	286**	Banjo fitting (For L Only)	1	431	Directional arrow label	1
75	Oil sump	1	176	Hex nut	1	285S-1**	Sealing ring (L / NM) for 285**	1	432	Warning Label (hot/read manual/noise)	1
79	Sheet metal baffle	1	177	Stud bolt	1	285S-1**/***	Sealing ring (For L & NM) for 285**	1	470*	BSLM hydraulic fitting	1
83	Oil sight glass	1	185	Gasket, Cylinder	1	285S-2**	Sealing ring (L / NM) for 285**	3	470S*-1	Sealing ring for 470	1
84	Gasket, Oil sight glass	1	186	Allen bolt	5	285S-2**/***	Sealing ring (For L & NM) for 285**	1	470S*-2	Sealing ring for 470	1
88	Plug, Oil fill	1	187	Spring Lock washer	5	290**	Oil return tube (L only)	1	471*	Oil Tube(C)	1
89	O-Ring, Oil fill plug	1	189	Stud	2	291**	Elbow hydraulic fitting (L only)	1	473*	Fitting	1
95	Plug, Oil drain	1	190	Spring Lock washer	2	291**(SC)	Elbow hydraulic fitting ( For L only)	1	474*	Gas Ballast	1
96	O-Ring, Oil drain plug	1	191	Hex nut	2	295S***	Sealing ring (NM only) for 295**	2	477*	Ball valve	1
99	Threaded fitting	1	205	Side cover plate	1	295***	Oil return valve (NM only)	1	480*	Gas Ballast Kit	1
100	oil filter	1	206	Gasket, Side cover plate	1	296***	Banjo fitting (NM only)	1	490	Gasket Kit	1
105	Oil sump cover plate	1	207	Allen bolt	12	297***	Oil Return tube (NM only)	1	500	Maintenance Kit	1
106	Gasket, Oil sump cover	1	208	Sealing ring	12	300	Motor mounting bracket (IEC)	1	510	Conversion kit, L type	1
107	Allen bolt	4	218	Socket (NEW)	1	301	Stud	3	520	Conversion kit, N Type	1
108	Sealing ring for	4	219	Straight hydraulic fitting	1	302	Spring Lock washer	3	530	Conversion kit, NM Type	1
115	Filter bracket	1	220	Straight hydraulic fitting	1	303	Hex nut	3	540	Conversion Kit, F type (with GB Kit)	1
120	Exhaust filter	4	221	BSLM hydraulic fitting (NEW)	1	310	Coupling set (310 ~313), IEC	1	541	Conversion Kit, F type (w/o GB Kit)	1
121	O-Ring, Exhaust filter	4	221S-1	Sealing Ring for 221	1	311	Coupling Half, Pump Side	1	600	Motor(NEMA)	1
125	Filter spring	4	221S-2	Sealing Ring for 221	1	312	Connection Bolt with rubber boot	6	600.3	Motor Fan(NEMA)	1
126	Slotted cheese head screw	4	222	Elbow Hydraulic fitting (OLD)	1	312.3	Rubber Boot	6	600.4	Motor Fan Cover(NEMA)	1
136	Gasket, Service cover	1	222	BSLM Hydraulic fitting (NEW)	1	314	Hexagon head screw for 50322B	5	601	Allen Bolt (NEMA)	4
137	Sealing ring	2	222S-1	Sealing Ring for 221	1	316	Set screw ( Pump side)	2	602	Spring lock washer(NEMA)	4
138	Allen bolt	2	222S-2	Sealing Ring for 221	1	317	Set screw ( Motor side)	2	610	Motor Mounting Flange (NEMA)	1
139	Service cover	1	223	Elbow Hydraulic fitting	1	321	Pump shaft end fan	1	612	Coupling set (311 + 312 + 613), NEMA	1
140	Allen bolt	4	230	Oil tube (A)	1	322	Motor shaft end fan for IEC/ NEMA Motor	1	613	Coupling half, Motor side(NEMA)	1
141	Gasket, Separator cover	1	231	Oil tube (B)	1	322	Motor shaft end fan for IEC Motor	1	622	Motor Shaft End Fan for Nema motor	1
142	Separator cover plate	1	232	Oil tube (A-1)	1	340	Fan hood	1	623	Collar for fan(# 622), for NEMA motor	1
143	Sealing ring	4	233	BSLM hydraulic fitting	1	341	Hexagon head screw	3	800	Inlet Air Filter	1
144	Perforated metal screen	2	233S-1	Sealing Ring for 233	1	390	Adapter for eye bolt	1	900	Pump Module	1

# L230, L305

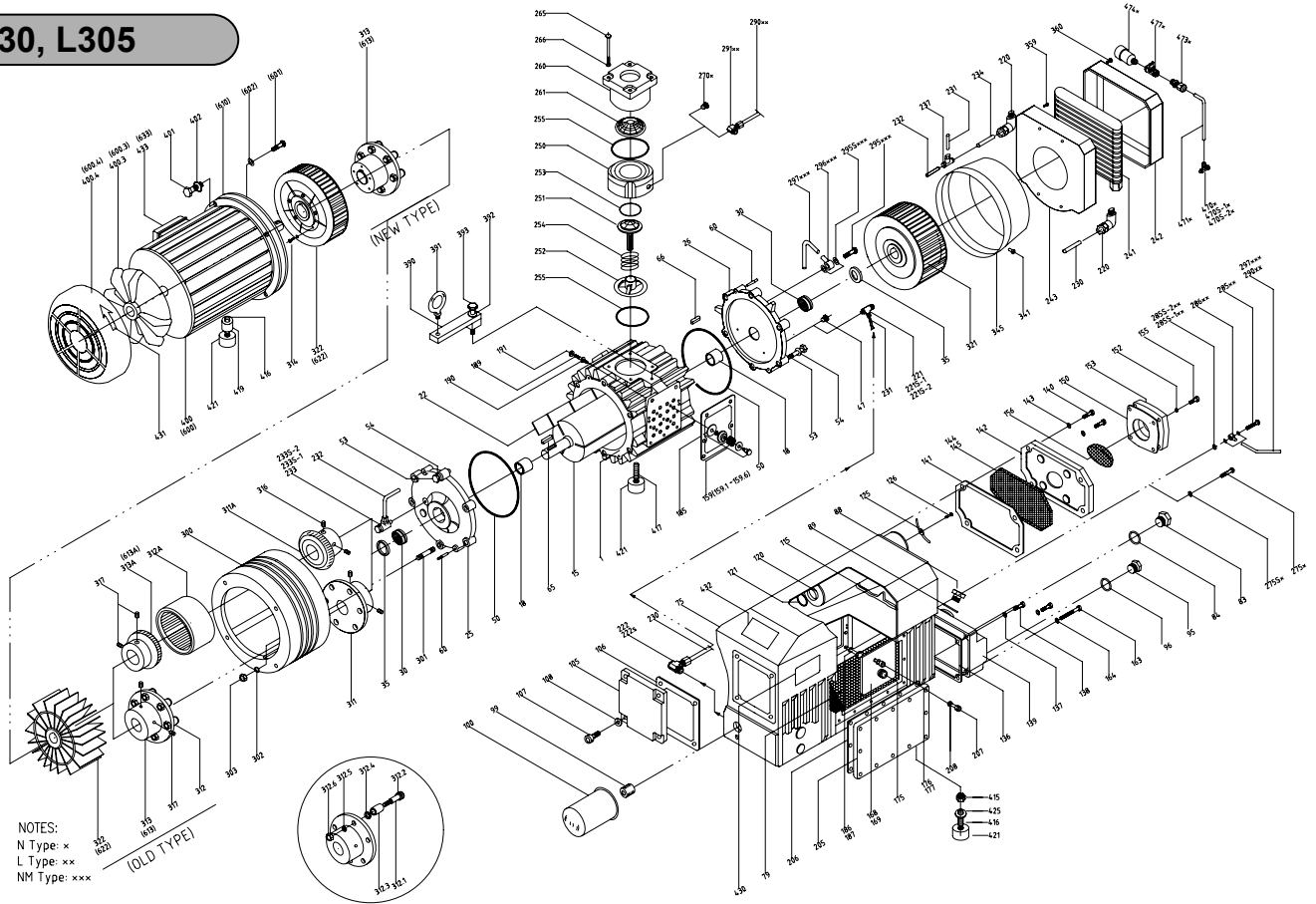

Pos. No.	Description	Qty	Pos. No.	Description	Qty	Pos. No.	Description	Qty	Pos. No.	Description	Qty
1	Cylinder	1	152	Sealing ring	4	250	Inlet flange, Lower housing	1	393	Hexagon head screw	1
15	Rotor	1	153	Exhaust threaded cover	1	251	Check valve plate	1	400	Motor (IEC)-50Hz	1
18-1	Sleeve, Bearing	2	155	Allen bolt	4	252	Check valve guide	1	400	Motor (IEC)-60Hz	1
18-2	Sleeve, Bearing	2	156	Outlet screen	1	253	O-Ring, Check valve plate	1	400.3	Motor Fan (IEC)	1
22	Vane	3	159	Exhaust valve ass'y (159.1~ 159.6)	4	254	Check valve spring	1	400.4	Motor Fan Cover (IEC)	1
25	A-End plate	1	159-1	Exhaust valve fixed bolt	4	255	O-Ring, In-let part	2	401	Hexagon head screw	4
26	B-End plate	1	159-2	Exhaust valve washer	4	260	Inlet flange , Upper housing	1	402	Spring Lock washer	4
30	Bearing	2	159-3	Exhaust valve spring	4	261	Inlet screen (conical)	1	415	Hex nut	1
35	Shaft seal	2	159-4	Exhaust valve plate	4	265	Allen bolt	4	416	Slotted set screw	2
47	Plug	1	159-5	Exhaust valve lock nut	4	266	Spring Lock washer	4	417	Slotted set screw	1
50	O-Ring, End plate	2	159-6	Exhaust valve seat plate	4	270*	Plug (N only)	1	419	Sleeve	1
53	Hexagon head screw	9	163	Allen bolt	2	275*	Oil return valve (N only)	1	421	Rubber foot	3
54	Spring Lock washer	9	164	Sealing ring	2	275S*	Sealing ring (N only) for 275*	1	423	Spring Lock Washer	1
60	Taper Pin	4	168	O-Ring, Valve cover plate	1	285**/****	Oil Recirculation Screw (L / NM)	1	425	Washer	1
65	A-Shaft key	1	169	Valve cover plate	1	286**/****	BSLM Hyd. Fitting (L / NM)	1	430	Name plate	1
66	B-Shaft key	1	175	Plug	1	285S-1**	Sealing ring (L / NM) for 285**	1	431	Directional arrow label	1
75	Oil sump	1	176	Hex nut	1	285S-2**	Sealing ring (L / NM) for 285**	3	470*	BSLM hydraulic fitting	1
79	Sheet metal baffle	1	177	Stud bolt	1	290**	Oil return tube (L only)	1	470S*-1	Sealing ring for 470	1
83	Oil sight glass	1	185	Gasket, Cylinder	1	291**(SC)	Elbow hydraulic fitting (L only)	1	470S*-2	Sealing ring for 470	1
84	Gasket, Oil sight glass	1	186	Allen bolt	5	291**(STD)	Elbow hydraulic fitting (L only)	1	471*	Tube(C)	1
88	Plug, Oil fill	1	187	Spring Lock washer	5	295S***	Sealing ring (NM only) for 295**	2	473*	Fitting	1
89	O-Ring, Oil fill plug	1	189	Stud	2	295***	Oil return valve (NM only)	1	474*	Gas ballast	1
95	Plug, Oil drain	1	190	Spring Lock washer	2	296***	Banjo fitting (NM only)	1	477*	Ball valve	1
96	O-Ring, Oil drain plug	1	191	Hex nut	2	297***	Oil Return tube (NM only)	1	480*	Gas Ballast Kit	1
99	Threaded fitting	1	205	Side cover plate	1	300	Motor mounting bracket	1	490	Gasket Kit	1
100	oil filter	1	206	Gasket, Side cover plate	1	301	Stud	3	500	Maintenance Kit	1
105	Oil sump cover plate	1	207	Allen bolt	12	302	Spring Lock washer	3	510	Conversion kit, L type	1
106	Gasket, Oil sump cover	1	208	Sealing ring	12	303	Hex nut	3	520	Conversion kit, N Type	1
107	Allen bolt	4	219	Straight hydraulic fitting	1	310	Coupling set (310 ~313)	1	530	Conversion kit, NM Type	1
108	Sealing ring	4	220	Straight hydraulic fitting	2	311	Coupling Half, Pump Side	1	540	Conversion Kit, F type (with GB Kit)	1
115	Filter bracket	1	221	BSLM hydraulic fitting	1	312	Connection Bolt with rubber boot	6	541	Conversion Kit, F type (w/o GB Kit)	1
120	Exhaust filter	4	221S-1	Sealing Ring for 221	1	312.3	Rubber Boot	0	600	Motor (NEMA)	1
121	O-Ring, Exhaust filter	4	221S-2	Sealing Ring for 221	1	313	Coupling Half, Motor Side	1	600.3	Motor Fan (NEMA)	1
125	Filter spring	4	222	BSLM Hydraulic fitting	1	314	Hexagon head screw for 50322B	5	600.4	Motor Fan Cover (NEMA)	1
126	Slotted cheese head screw	4	222S	Sealing Ring	2	316	Set screw (Pump side)	2	601	Allen Bolt (NEMA)	4
136	Gasket, Service cover	1	230	Oil tube (A-1)	1	317	Set screw ( Motor side)	2	602	Spring lock washer(NEMA)	4
137	Sealing ring	2	231	Oil tube (B-1)	1	321	Pump shaft end fan	1	610	Motor Mounting Flange (NEMA)	1
138	Allen bolt	2	232	Oil tube (B-2)	1	322	Motor shaft end fan for IEC Motor	1	612	Coupling set (311 + 312 + 613), (NEMA)	1
139	Servic cover	1	233	BSLM hydraulic fitting	1	322	Motor shaft end fan for IEC/ NEMA Motor	1	613	Coupling, Motor side (NEMA)	1
140	Allen bolt	4	233S-1	Sealing Ring for 233	1	341	Hexagon head screw	3	622	Motor Shaft End Fan for Nema motor	1
141	Gasket, Separator cover	1	233S-2	Sealing Ring for 233	1	345	Fan Cover	1	623	Collar for fan(# 622), for NEMA motor	0
142	Separator cover plate	1	234	Oil Tube (A-2)	1	359	Allen Bolt	4			
143	Sealing ring	4	237	BLT Hydraulic fitting	1	360	Allen Bolt	4			
144	Perforated metal screen	2	241	Radiator	1	390	Adapter for eye bolt	1			
145	Strainer, baffle	1	242	Cover( front), radiator	1	391	Eye bolt	1	800	Inlet Air Filter	1
150	Gasket, Exhaust cover	1	243	Cover( rear), radiator	1	392	Spring Lock washer	1	900	Pump Module	1

# L250E

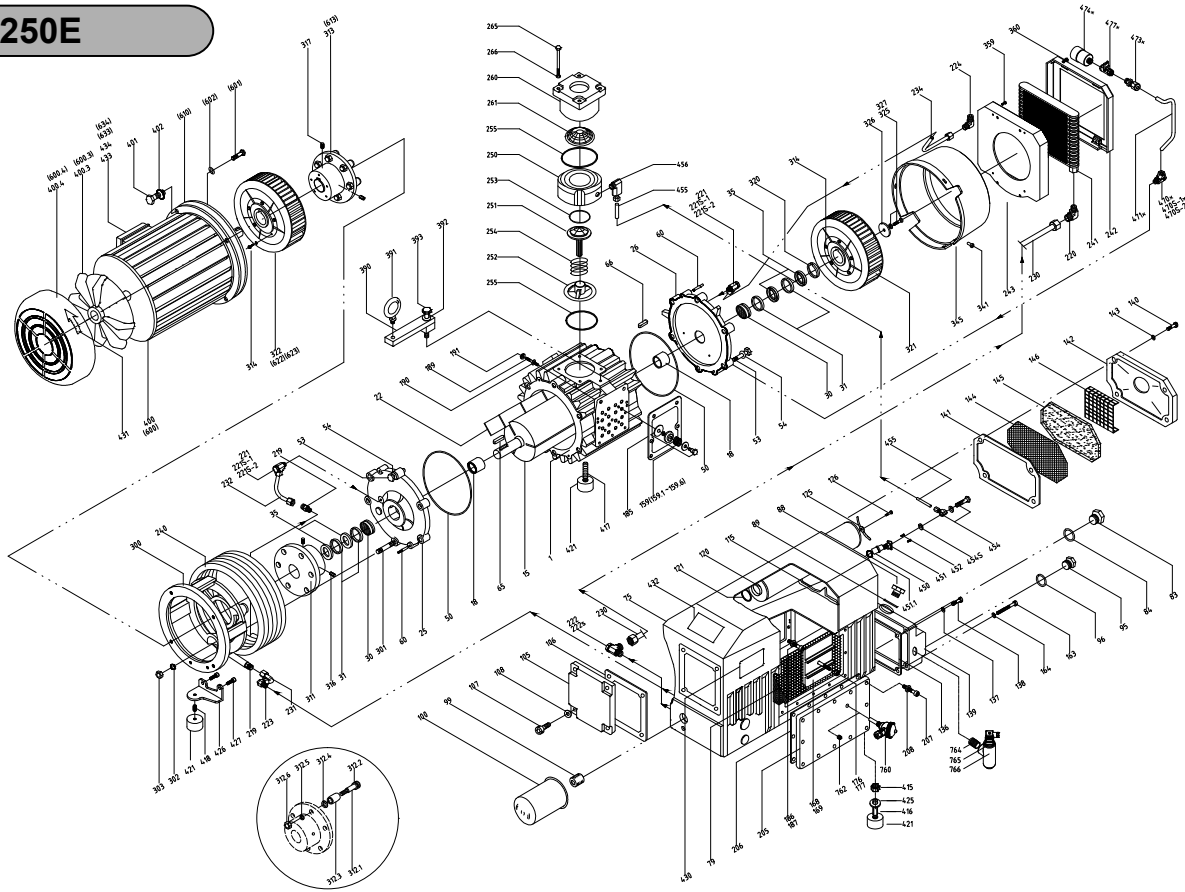

Pos. No.	Description	L250E Qty	Pos. No.	Description	L250E Qty	Pos. No.	Description	L250E Qty	Pos. No.	Description	L250E Qty
1	Cylinder	1	159-3	Exhaust valve spring	4	266	Spring Lock washer	4	451.1	O-Ring for Nozzle Assembly	1
15	Rotor	1	159-4	Exhaust valve plate	4	300	Motor mounting bracket	1	452	Bolt	2
18	Sleeve, Bearing	4	159-5	Exhaust valve lock nut	4	301	Stud	3	454	Banjo fitting	1
22	Vane	3	159-6	Exhaust valve seat plate	4	302	Spring Lock washer	3	454S	Sealing ring for 454	2
25	A-End plate	1	163	Allen bolt	2	303	Hex nut	3	455	Oil Return tube	1
26	B-End plate	1	164	Sealing ring	2	310	Coupling set (310 ~313)	1	456	Elbow hydraulic fitting	1
30	Bearing	2	168	O-Ring, Valve cover plate	1	311	Coupling Half, Pump Side	1	470*	BSLM hydraulic fitting	1
35	Shaft seal	2	169	Valve cover plate	1	312	Connection Bolt with rubber boot	6	470S*-1	Sealing ring for 470	1
50	O-Ring, End plate	2	176	Hex nut	1	312.3	Rubber Boot	6	470S*-2	Sealing ring for 470	1
53	Hexagon head screw	9	177	Stud bolt	1	313	Coupling Half, Motor Side	1	471*	Oil tube(C)	1
54	Spring Lock washer	9	185	Gasket, Cylinder	1	314	Hexagon head screw for 50322B	10	473*	Fitting	1
60	Taper Pin	4	186	Allen bolt	5	316	Set screw (Pump side)	2	474*	Gas ballast	1
65	A-Shaft key	1	187	Spring Lock washer	5	317	Set screw ( Motor side)	2	477*	Ball valve	1
66	B-Shaft key	1	189	Stud	2	321	Pump shaft end fan	1	480*	Gas Ballast Kit	1
75	Oil sump	1	190	Spring Lock washer	2	322	Motor shaft end fan for IEC Motor	1	490	Gasket Kit	1
79	Sheet metal baffle	1	191	Hex nut	2	322	Motor shaft end fan for IEC/ NEMA Motor	1	500	Maintenance Kit	1
83	Oil sight glass	1	205	Side cover plate	1	325	Washer, Spring lock	1	550	Inlet Check Valve Kit	1
84	Gasket, Oil sight glass	1	206	Gasket, Side cover plate	1	326	Washer, plain	1	600	Motor (NEMA)	1
88	Plug, Oil fill	1	207	Allen bolt	12	327	Hexagon bolt	1	600.3	Motor Fan (NEMA)	1
89	O-Ring, Oil fill plug	1	208	Sealing ring	12	341	Hexagon head screw	3	600.4	Motor Fan Cover (NEMA)	1
95	Plug, Oil drain	1	219	Straight hydraulic fitting	2	345	Fan Cover	1	601	Allen Bolt (NEMA)	4
96	O-Ring, Oil drain plug	1	220	BSLM hydraulic fitting	1	359	Allen Bolt	4	602	Spring lock washer(NEMA)	4
99	Threaded fitting	1	221	BSLM hydraulic fitting	2	360	Allen Bolt	4	610	Motor Mounting Flange adapter (NEMA)	1
100	oil filter	1	221S-1	Sealing Ring for 221	2	390	Adapter for eye bolt	1	612B	Coupling set (311 + 312 + 613), (NEMA)	1
105	Oil sump cover plate	1	221S-2	Sealing Ring for 221	2	391	Eye bolt	1	613B	Coupling half, Motor side (NEMA)	1
106	Gasket, Oil sump cover	1	222	BSLM Hydraulic fitting	1	392	Spring Lock washer	1	622	Motor Shaft End Fan for Nema motor	1
107	Allen bolt	4	222S	Sealing Ring	2	393	Hexagon head screw	1	623	Collar for fan# 622), for NEMA motor	1
108	Sealing ring	4	223	Elbow Hydraulic Fitting	1	400	Motor (IEC)-50Hz	1	623	Collar for fan# 622), for NEMA motor	1
115	Filter bracket	1	224	BLM hydraulic fitting	1			1	634	Terminal board (NEMA)	1
120	Exhaust filter	4	230	Oil tube (A-1)	1	400	Motor (IEC)-60Hz	1			
121	O-Ring, Exhaust filter	4	231	Oil tube (B-1)	1	400.3	Motor Fan (IEC)	1	760	Temperature Switch	1
125	Filter spring	4	232	Oil tube (B-2)	1	400.4	Motor Fan Cover (IEC)	1	762	Plug	1
126	Slotted cheese head screw	4	234	Oil tube (B-3)	1	401	Hexagon head screw	4	764	Nipple	1
136	Gasket, Service cover	1	237	BLT Hydraulic fitting	1	402	Spring Lock washer	4	765	Level switch	1
137	Sealing ring	2	240	Cooling Spiral Coil	1	415	Hex nut	1	766	Level switch housing	1
138	Allen bolt	2	241	Radiator	1						
139	Service cover	1	242	Cover (front), radiator	1	416	Slotted set screw	1			
140	Allen bolt	4	243	Cover (rear), radiator	1	417	Slotted set screw	2			
141	Gasket, Separator cover	1	250	Inlet flange, Lower housing	1	418	Slotted set screw	1			
142	Separator cover plate	1	251	Check valve plate	1	421	Rubber foot	3			
143	Sealing ring	4			1	425	Washer	1			
			252	Check valve guide	1	426	Bracket for rubber foot	1			
144	Perforated metal screen	1	253	O-Ring, Check valve plate	1	427	Allen bolt	2			
145	Strainer, baffle	1	254	Check valve spring	1	430	Name plate	1			
146	Perforated metal screen	1	255	O-Ring, Inlet part	2	433	Terminal board	1			
159	Exhaust valve ass'y (159.1~ 159.6)	4	260	Inlet flange , Upper housing	1	434	Rubber gasket	1			
159-1	Exhaust valve fixed bolt	4	261	Inlet screen (conical)	1	450	Float	1	800	Inlet Air Filter	1
159-2	Exhaust valve washer	4	265	Allen bolt	4	451	Nozzle Assembly	1	900	Pump Module	1

# L305B

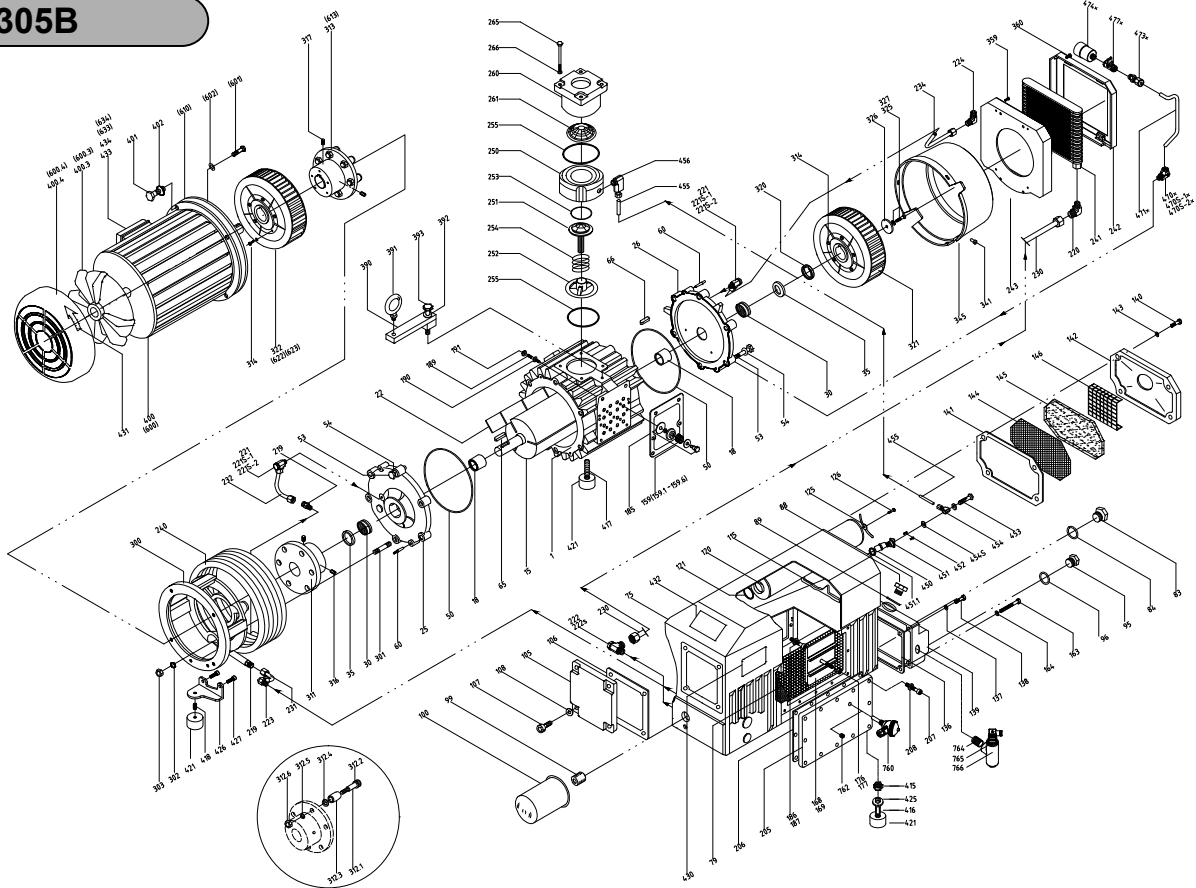

Pos. No.	Description	L305B Qty	Pos. No.	Description	L305B Qty	Pos. No.	Description	L305B Qty	Pos. No.	Description	L305B Qty
1	Cylinder	1	159-2	Exhaust valve washer	4	265	Allen bolt	4	450	Float	1
15	Rotor	1	159-3	Exhaust valve spring	4	266	Spring Lock washer	4	451	Nozzle Assembly	1
18	Sleeve, Bearing	4	159-4	Exhaust valve plate	4	300	Motor mounting bracket	1	451.1	O-Ring for Nozzle Assembly	1
22	Vane	3	159-5	Exhaust valve lock nut	4	301	Stud	3	452	Bolt	2
25	A-End plate	1	159-6	Exhaust valve seat plate	4	302	Spring Lock washer	3	453	Bolt for banjo fitting	1
26	B-End plate	1	163	Allen bolt	2	303	Hex nut	3	454	Banjo fitting	1
30	Bearing	2	164	Sealing ring	2	310	Coupling set (310 ~313)	1	454S	Sealing ring for 454	2
35	Shaft seal	2	168	O-Ring, Valve cover plate	1	311	Coupling Half, Pump Side	1	455	Oil Return tube	1
50	O-Ring, End plate	2	169	Valve cover plate	1	312	Connection Bolt with rubber boot	6	456	Elbow hydraulic fitting	1
53	Hexagon head screw	9	176	Hex nut	1	312.3	Rubber Boot	6	470*	BSLM hydraulic fitting	1
54	Spring Lock washer	9	177	Stud bolt	1	313	Coupling Half, Motor Side	1	470S*-1	Sealing ring for 470	1
60	Taper Pin	4	185	Gasket, Cylinder	1	314	Hexagon head screw for 50322B	10	470S*-2	Sealing ring for 470	1
65	A-Shaft key	1	186	Allen bolt	5	316	Set screw (Pump side)	2	471*	Oil tube(C)	1
66	B-Shaft key	1	187	Spring Lock washer	5	317	Set screw ( Motor side)	2	473*	Fitting	1
75	Oil sump	1	189	Stud	2	320	Spacer for fan	1	474*	Gas ballast	1
79	Sheet metal baffle	1	190	Spring Lock washer	2	321	Pump shaft end fan	1	477*	Ball valve	1
83	Oil sight glass	1	191	Hex nut	2	322	Motor shaft end fan for IEC Motor	1	480*	Gas Ballast Kit	1
84	Gasket, Oil sight glass	1	205	Side cover plate	1	322	Motor shaft end fan for IEC/ NEMA Motor	1	490	Gasket Kit	1
88	Plug, Oil fill	1	206	Gasket, Side cover plate	1	325	Washer, Spring lock	1	500	Maintenance Kit	1
89	O-Ring, Oil fill plug	1	207	Allen bolt	12	326	Washer, plain	1	510	Conversion kit, L type	1
95	Plug, Oil drain	1	208	Sealing ring	12	327	Hexagon bolt	1	520	Conversion kit, N Type	1
96	O-Ring, Oil drain plug	1	219	Straight hydraulic fitting	2	341	Hexagon head screw	3	530	Conversion kit, NM Type	1
99	Threaded fitting	1	220	BLM hydraulic fitting	1	345	Fan Cover	1	540	Conversion Kit, F type (with GB Kit)	1
100	oil filter	1	221	BSLM hydraulic fitting	2	359	Allen Bolt	4	541	Conversion Kit, F type (w/o GB Kit)	1
105	Oil sump cover plate	1	221S-1	Sealing Ring for 221	2	360	Allen Bolt	4	550	Inlet Check Valve Kit	1
106	Gasket, Oil sump cover	1	221S-2	Sealing Ring for 221	2	390	Adapter for eye bolt	1	600	Motor (NEMA)	1
107	Allen bolt	4	222	BSLM Hydraulic fitting	1	391	Eye bolt	1	600.3	Motor Fan (NEMA)	1
108	Sealing ring	4	222S	Sealing Ring	2	392	Spring Lock washer	1	600.4	Motor Fan Cover (NEMA)	1
115	Filter bracket	1	223	Elbow hydraulic fitting	1	393	Hexagon head screw	1	601	Allen Bolt (NEMA)	4
120	Exhaust filter	4	224	BLM hydraulic fitting	1	400	Motor (IEC)-50Hz	1	602	Spring lock washer(NEMA)	4
121	O-Ring, Exhaust filter	4	230	Oil tube (A-1)	1	400	Motor (IEC)-60Hz	1	610	Motor Mounting Flange adapter (NEMA)	1
125	Filter spring	4	231	Oil tube (B-1)	1	400,3	Motor Fan (IEC)	1	612B	Coupling set (311 + 312 + 613), (NEMA)	1
126	Slotted cheese head screw	4	232	Oil tube (B-2)	1	400,4	Motor Fan Cover (IEC)	1	613B	Coupling half, Motor side (NEMA)	1
136	Gasket, Service cover	1	234	Oil tube (B-3)	1	401	Hexagon head screw	4	622	Motor Shaft End Fan for Nema motor	1
137	Sealing ring	2	240	Cooling spiral Coil	1	402	Spring Lock washer	4	623	Collar for fan(# 622), for NEMA motor	1
138	Allen bolt	2	241	Radiator	1	415	Hex nut	1	623	Collar for fan(# 622), for NEMA motor	1
139	Service cover	1	242	Cover (front), radiator	1	416	Slotted set screw	1	634	Terminal board (NEMA)	1
140	Allen bolt	4	243	Cover (rear), radiator	1	417	Slotted set screw	1	760	Temperature Switch	1
141	Gasket, Separator cover	1	250	Inlet flange, Lower housing	1	418	Slotted set screw	1	762	Plug	1
142	Separator cover plate	1	251	Check valve plate	1	421	Rubber foot	3	764	Nipple	1
143	Sealing ring	4	252	Check valve guide	1	425	Washer	1	765	Level switch	1
144	Perforated metal screen	1	253	O-Ring, Check valve plate	1	426	Bracket for Rubber foot	1	766	Level switch housing	1
145	Strainer, baffle	1	254	Check valve spring	1	427	Allen bolt	2			
146	Perforated metal screen	1	255	O-Ring, Inlet part	2	430	Name plate	1			
159	Exhaust valve ass'y (159.1~ 159.6)	4	260	Inlet flange , Upper housing	1	433	Terminal board	1	800	Inlet Air Filter	1
159-1	Exhaust valve fixed bolt	4	261	Inlet screen (conical)	1	434	Rubber gasket	1	900	Pump Module	1

**AIRTECH<sup>®</sup>**  
*VACUUM*

301 Veterans Boulevard  
Rutherford, NJ 07070  
Tel: 1 888 222 9940  
Fax: 201 569 1696  
[airtech@airtechusa.com](mailto:airtech@airtechusa.com)

**AIRTECH<sup>®</sup>** SOUTH  
*VACUUM*

2121 Newmarket Pkwy. Suite 110  
Marietta, GA 30067  
Tel: 770 690 0700  
Fax: 770 690 0709  
[airtechsouth@airtechusa.com](mailto:airtechsouth@airtechusa.com)

**AIRTECH<sup>®</sup>** WEST  
*VACUUM*

42 Digital Drive #9  
Novato, CA 94949  
Tel: 415 382 9000  
Fax: 415 382 9700  
[airtechwest@airtechusa.com](mailto:airtechwest@airtechusa.com)

**AIRTECH<sup>®</sup>** CHINA  
*VACUUM*

2nd Building,  
Jiangbian Second Industrial Park  
Songgang Town, Bao'an District  
Shenzhen, China  
Tel: +86 755 81730991(Ext.8018)  
Fax: +86 755 81730986  
[www.airtechchina.com](http://www.airtechchina.com)

**AIRTECH<sup>®</sup>**  
*EUROPE*

Pfaffenpfad 5  
D-97440 Werneck  
Germany  
Tel: +49 9722 943 96 0  
Fax: +49 9722 943 96 29  
[www.airtecheu.com](http://www.airtecheu.com)

**AIRTECH<sup>®</sup>** ASIA  
*VACUUM*

Pfaffenpfad 5  
D-97440 Werneck  
Germany  
Tel: +49 9722 943 96 0  
Fax: +49 9722 943 96 29  
[www.airtechas.com](http://www.airtechas.com)