

AIRTECH[®] VACUUM

Operating and Maintenance Instructions AD Series Boosters



INSTALLATION & OPERATING MANUAL AD BOOSTER

Table of Contents

Section:	Page Number:
Safety	5
1 Description	7
1.1 Overview	7
1.2 Features	7
1.3 Principle of Operation	8
1.4 Bypass Valve Operation	9
2 Performance Specifications	9
2.1 Performance Curve	9
2.2 Technical Data	12
3 Installation	12
3.1 Pipe Connections	12
3.2 Electrical Connections	13
3.3 Lubrication	14
4 Operation	14
4.1 Pre-Start Check	14
4.2 Start up	14
4.3 Operation	15
4.4 Shut Down	15
5 Maintenance	15
5.1 General	15
5.2 Oil Change	15
5.3 Cleaning The Pumping Chamber	16
6 Troubleshooting	17
7 Exploded View Drawings/Parts List	19
8 Dimensional Drawings	25
Warranty Statement	26

Safety

Please read this manual carefully and follow the instructions carefully during the installation, operation and maintenance of the unit. Only trained personnel should operate and maintain the product.

For further information about safe operation and maintenance, please contact Airtech Vacuum.

Warning: Failure to observe the following precautions may result in serious injury or damage to the unit.

1. The power supply must be disconnected prior to any maintenance procedures.
2. Never start the unit with any of the parts removed as serious damage may result.
3. Always make sure the exhaust pipe is clear of any foreign materials.
4. The pressure differential of the booster must not exceed the unit's capacity, even if exhaust gas is to be collected or stored in a tank.
5. The standard unit is not explosion-proof. If the application requires an explosion-proof unit, please contact Airtech Vacuum.
6. The pump is not suitable for pumping the following gases: flammable gas, explosive gas, gas with high oxygen content, radioactive gas, and toxic gas.
7. Check to ensure that the protective switch equipped in the motor circuit is suitable before starting the unit for the first time.
8. If the unit was stopped due to failure, it must be re-started in manual mode.
9. Never expose any part of the human body to vacuum.
10. Never operate the pump if the inlet or outlets have been removed.
11. If a frame or foundation is to be constructed for the unit, it must be level.
12. The area surrounding the unit should be free of flammable materials. During pump operation, the external surface temperature of the unit may exceed 80°
13. The temperature of the piping or any other accessories attached to the pump may also exceed 80°, take caution when handling any such attachments.

14. Avoid prolonged exposure to high decibel levels and use ear protection when necessary.
15. Be careful not to allow small objects such as screws, nuts, washers, welding slag, iron beads to be sucked into the pump.
16. The unit is unsuitable for applications that produce grinding material, grinding powder and condensable steam. Adhesive or heavy-viscosity deposits may remain after procedures unless a separator is employed.
17. Before pumping vapors, it is necessary to operate the pump to attain its operating temperature, during this time the pump should be disconnected from the system to prevent steam from condensing in the pump.
18. The exhaust pipe should be fitted at a downward angle to prevent liquid from entering the pump.
19. Both sides of the inlet and outlet can be equipped with corrugated pipe to prevent the transfer of vibration from the pump to other parts of the system.

Disposal of Waste Oil

Please dispose of waste oil properly and take care not to mix the waste oil with other materials.

Waste oil produced due to mechanical wear, oxidation, or high temperatures can be disposed of by a waste oil treatment system.

The name of the contaminant contained in the waste oil should be marked clearly, and the contaminated waste oil must be disposed of in accordance with local regulations.

1. Description

1.1 Overview

The operating principle of the AD Booster is similar to that of a roots blower. Operating as a mechanical vacuum pump equipped with a pair of dual-lobe rotors rotating at high speed, roots vacuum pumps can achieve gas compression by the rotation of the two figure-eight shaped rotors in the pump housing. Since the bypass allows the pump to operate only in the low-pressure range, a high compression ratio is possible. The pump is designed to be used as a vacuum booster, it should not be used to exhaust gas directly to atmospheric pressure. The pumped gas can be released into the atmosphere via the backing vacuum pump, as illustrated in Figure 1.

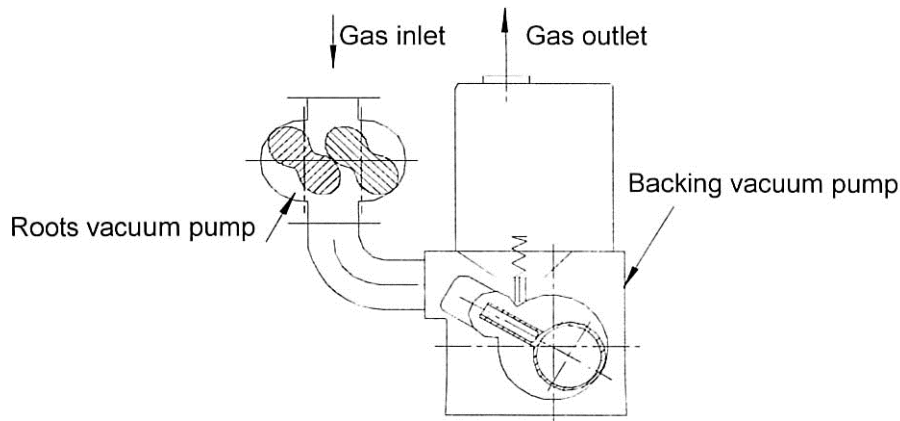

Fig. 1 Diagram of roots pump and backing pump

1.2 Features

- (1) Dry running due to tight clearances between the rotors and the pump housing allows lubricant free operation.
- (2) Symmetrical rotors allow more balanced, lower vibration operation.
- (3) Gas compression takes place outside the pump housing; therefore no exhaust valve is required, allowing the unit to be used for the pumping of condensable steam.
- (4) The unit can achieve ultimate vacuum quickly after start-up when paired with the proper backing pump.
- (5) The pump is equipped with a bypass valve to allow start-up simultaneously with the backing pump (do not attempt to operate without first starting the backing pump; motor sizing does not support direct atmospheric operation).

(6) The magnetic drive transmits shaft torque, allowing use of a static seal, meaning that there's no need for a framework oil seal or mechanical seal, resulting in zero leakage.

1.3 Principle of Operation

The principle of operation is explained in figure 2.

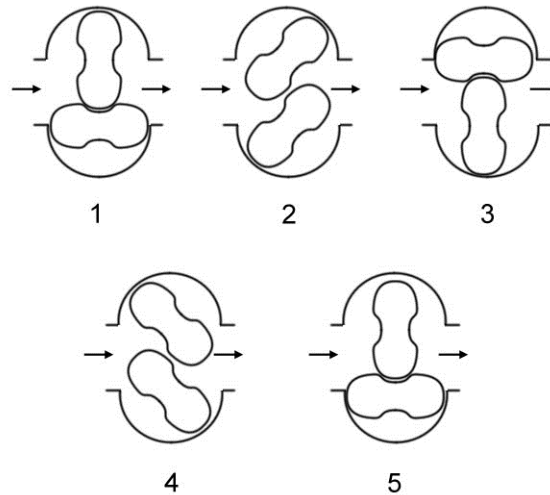

Fig 2. Principle of Operation of a Roots-type pump

During the operation the pumped gas enters the space between the rotors and the pump body via the gas inlet. At this time a rotor body will enclose the gas away from the inlet and the gas will be conveyed to the outlet with the continuous rotation of the rotors. In position (1) of Fig. 2, the gas in V_0 is enclosed, thus there is no compression or expansion. As the top of the rotor reaches the edge of the outlet, the gas is exhausted to the outlet side; thus compressed to the pressure at the outlet. Meanwhile, the inlet side of the rotor at the suction connection will draw in more gas.

The roots pump is operated under low inlet pressure. Due to the relatively high rotation speed of the rotor (3600 rpm), the linear speed of rotor surface is transmitted to the gas molecule, resulting in motion of the gas with increasing velocity and heat from the inlet to the outlet port of the blower.

A bypass is added to the pump design to allow the operation of the pump from atmospheric pressure during start-up (for short periods).

1.4 Bypass Valve Operation

The pump is equipped with a bypass valve between the inlet and outlet, which can limit the pressure differential between the inlet and outlet within a limited range. In the event of a pressure differential beyond the rated curve, the valve will automatically open to connect the inlet to outlet. If the pressure differential is lower than the rated value, the overflow valve will close automatically.

Various types of backing pumps can be chosen depending on the working conditions. For applications with a low-vacuum requirement or a situation involving large amounts of steam, dust, or mildly corrosive gases, the roots pump can be integrated with a two-stage liquid ring vacuum pump and piston vacuum pump. Selection of the backing pump is critical to determining the ultimate vacuum that can be attained as well as the power requirements of operation.

2 Performance specification

2.1 Performance Curve

Curves can be extrapolated to other models by taking ratios of the reported performance characteristics and applying the curves for the model shown.

The following curves are provided for reference:

- Figure 3: Curve of pumping speed and power consumption versus inlet pressure for AD500.
- Figure 4: Curve of pumping speed and power consumption versus inlet pressure for AD1200.
- Figure 5: Capacity curve for both AD500 and AD1200.
- Figure 6: Capacity curve for AD2600.

Please note that the curves for power consumption assume use of a backing pump with high vacuum capacity (end pressure of .001 Torr or lower) and therefore may not be applicable to all applications. Consult your Airtech sales representative for additional information and support.

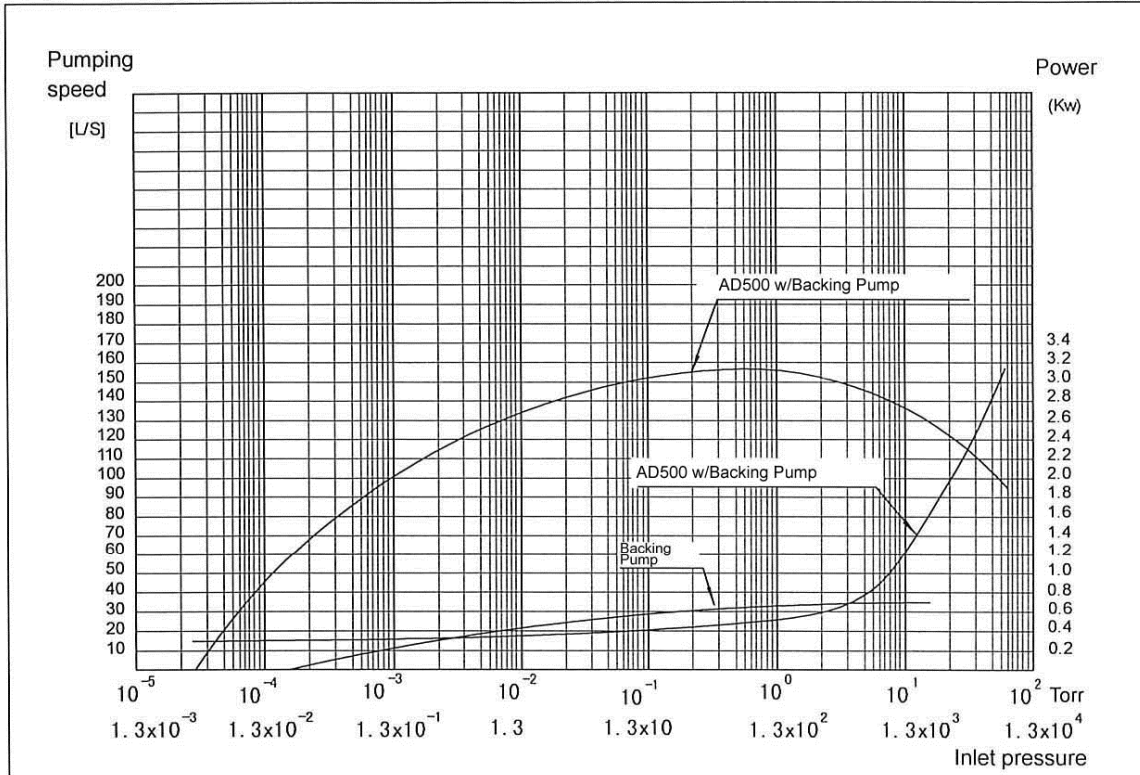

Fig. 3 Curve of pumping speed and power consumption versus inlet pressure for AD500/ High-Vac backing pump

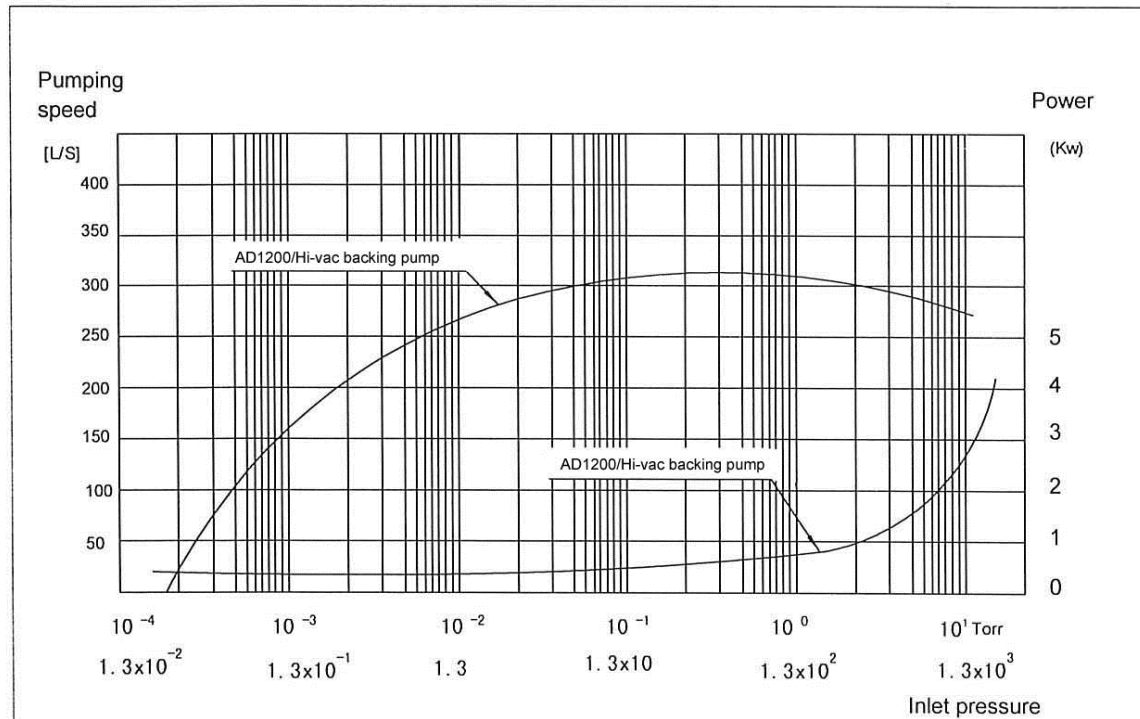

Fig. 4 Curve of pumping speed and power consumption versus inlet pressure for AD1200/ High-Vac backing pump

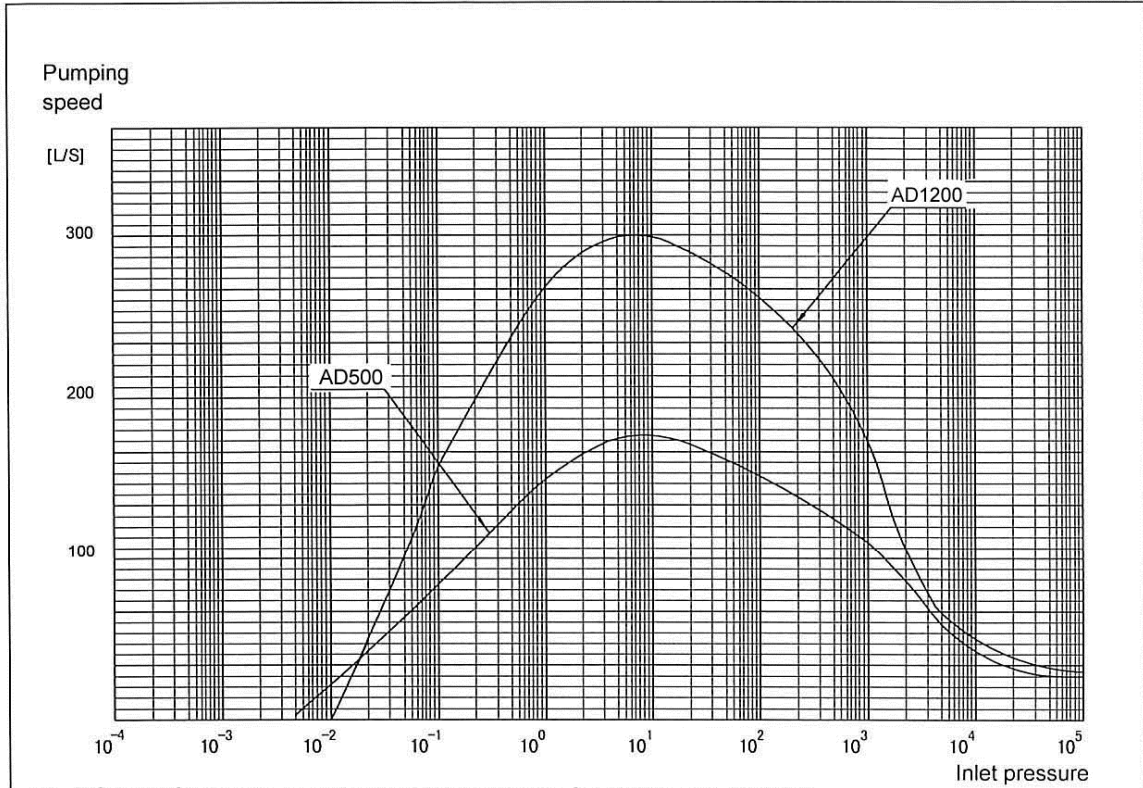

Fig. 5 Curve of pumping speed versus inlet pressure for AD500 and AD1200

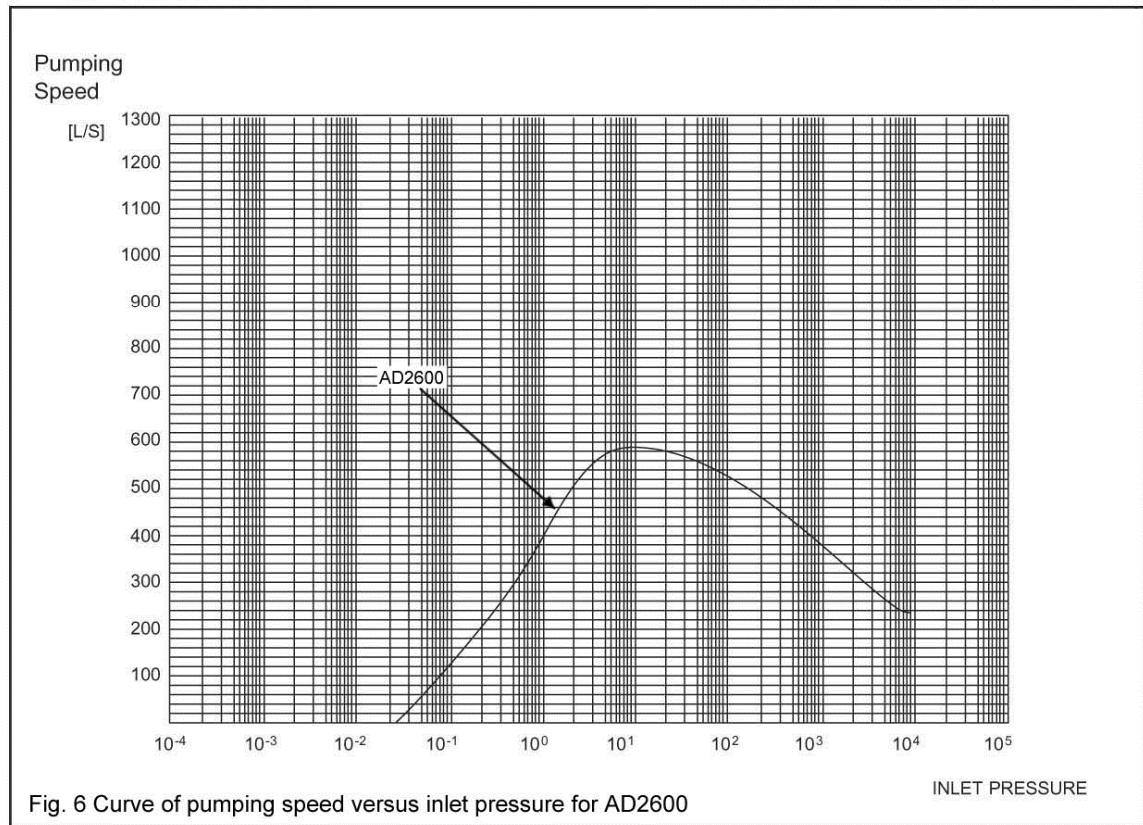

Fig. 6 Curve of pumping speed versus inlet pressure for AD2600

2.2 Technical Data

Model			AD500	AD1200	AD2600
Nominal Pumping Speed		L - S ⁻¹	70	300	600
		M ³ · h ⁻¹	540	1080	2160
Ultimate Pressure		Pa	3 x 10 ⁻²	3 x 10 ⁻²	3 x 10 ⁻²
Pressure Differential of relief valve		Pa	4.8 x 10 ³	5.8 x 10 ³	3.2 x 10 ³
Permissible Ambient Temperatures		°C	5-40	5-40	5-40
Main voltage at the motor, 60Hz		V	460	460	460
Motor Power, 60 Hz		kW	2.6	4.4	7.5
Rotation Speed, 50 Hz		RPM	3550	3550	3550
Protection		IP	54	54	54
Oil Capacity (Gear Box)		L	2.8	2.8	7.5
Flange Internal Diameter	inlet	Inches	3	4	6
	outlet				
Cooling Water Supply (when required)		L - h ¹	/	/	150
Weight with motor		Kg	220	310	790
Shipping weight		Kq	270	380	850
Noise level (under ultimate pressure)		dB(A)	72	74	76
Recommended backing pump (range based on typical operation)			L250	L250	L400
				L630	L630

3.0 Installation

3.1 Receipt and Mechanical Hook-up

1. Carefully remove the pump from its crate and check to ensure that the pump is not damaged prior to installation.
2. The area where the unit is to be installed should be clean and free of dust and debris. The air inlet of the pump should be provided with necessary accessories as recommended by Airtech for your specific application (for example, dust filters, condensers, pressure or temperature switches, etc...). In addition, ambient temperature should be between 5-40°C, and the maximum temperature rise

should be no higher than 100°C. Lower temperatures may cause problems at start-up due to oil viscosity, higher ones shorten the oil change intervals and may lead to greater wear.

3. The base can be installed on a concrete foundation or a steel frame as required, however the unit must be level to operate properly.
4. Install inlet and outlet piping to ensure no pipe stress is communicated to the unit. Support all piping independently of the unit – the unit is not designed to support piping and applying stress to the body of the unit can cause failure due to distortions during operation.
5. After installation, check the piping for leaks as leaks will negatively affect operation of the unit.
6. Piping leading to inlet should be kept fairly short, with as few joints and fittings as possible. The diameter of the pipe should be no smaller than that of the inlet.
7. Provide flexible connections such as metal bellows in the connecting pipe between the roots pump and the backing pump to isolate vibrations and protect both the AD pump and the backing pump from damage.
8. If vacuum must be maintained after shutdown, be sure to install a check valve (with suitable pressure loss characteristics) or an isolation valve at the blower inlet. Do not install a check valve between the unit and the backing pump without considering the pressure loss characteristics of the valve being installed.
9. For applications where solid particulates may be present, a filter should be installed at the intake port of the booster and monitored to avoid excessive pressure loss when clogged. For new installations, we recommend use of a start-up screen for all units.
10. It is necessary to use a suitable vacuum pump as a backing pump for the blower; never operate the roots pump alone. When operated with an oil-seal typed mechanical vacuum pump as its backing pump, avoid handling gases enriched with oxygen, explosive gas, gas which is corrosive to ferrous metal, or gas that reacts with vacuum oil.

3.2 Electrical Connections

Wire the motor and other control devices such as solenoid valves and temperature switch according to the voltage and current requirements indicated on the nameplate of each component. Turn the pump by hand after wiring is completed and make sure there are no obstructions and the pump turns freely. Then jog the motor momentarily to check the direction of rotation. If the pump does not rotate in the correct direction as marked on the drive end cover, interchange any two of the three-phase leads.

3.3 Lubrication

Under typical conditions, the pump is filled with lubricating oil when it leaves factory. We recommend the use of our ATO-3000 oil (MAX 3000), which can be ordered from Airtech.

4 Operation

4.1 Pre-start check

(1) Check to make sure the oil level in the gearbox and end cover is sufficient; the oil level should be up to the specified line on the sight glass. It is recommended that you first change the oil after the pump has been running for 500 hours, with changes of oil at 3000 hours or as required by the application thereafter.

(2) The air inlet should be equipped with filtering equipment if the intake gas contains powders or dusts. Handling of corrosive gases should be undertaken only after review with your Airtech sales representative.

(3) Check and retighten any loose connections and ensure the rotation direction of motor complies with the direction of arrow marked on pump.

4.2 Startup

- (1) Start the backing pump.
- (2) Open the suction valve of the roots pump.
- (3) Start the roots pump.
- (4) The rotation of the pump should be stable and without excessive vibration.
- (5) Pump should be stopped immediately and be examined if the temperature rise is higher than expected, if the reading of current meter changes suddenly, or any irregular noise or impacting sound is noticed during operation.

Caution: The operating pressure differential of the pump should be limited to within the allowable range of the bypass valve or motor overload may result. Louder than normal noise may be noticed during the start-up, however, it should fade away after reaching the operating vacuum. If it does not, try starting the backing pump first and cutting the roots pump in when the appropriate vacuum is achieved. If the problem is solved by this test, then the bypass valve is likely stuck and must be serviced prior to resuming normal operation. A simple test can be used to determine the permissible cut-in pressure: start the backing pump and allow free-wheeling of the pump. When the pump rotates, then the bypass valve has closed and the cut-in pressure has been reached.

4.3 Operation

The pump should never be run with the inlet or discharge pipe removed. The screws of the flanges on the suction and the pressure side must not be loosened in the presence of vacuum even when the pump is not running.

During operation of the roots pump, check the oil level and the condition of the oil in the oil level sight glass from time to time. Correct as required (see section 5.2). Normally, the oil is light brown. If it turns dark, this is a sign of early aging due to excessively high temperatures.

4.4 Shut down

- (1) Close the intake valve on inlet pipe.
- (2) Shut down the roots pump.
- (3) Shut down the backing pump.
- (4) Residual water in water jacket (when used) must be drained completely when storing the pump for a long period of time in a cold area to avoid freezing damage.

5 Maintenance

5.1 General

1. Make sure the area surrounding the unit is clean and dry
2. Check the lubricating oil frequently in each part and refill if necessary. Change any contaminated oil immediately and confirm the proper seal when retightening the oil screw plug.
3. Ensure that the operating pressure differential of pump is limited to the allowable range of overflow valve, to avoid motor damage.
4. Never hit the unit with a hammer when dismantling.
5. Disconnect the electrical power before disassembling the pump and vent the pump to atmospheric pressure. Make absolutely sure that the pump cannot be accidentally started.
6. If the pump has been pumping harmful substances, suitable safety measures should be introduced.
7. All maintenance and cleaning work must be carried out only by suitably trained personnel.

5.2 Oil Change

There are two locations on the roots pump that have oil lubrication that requires service during oil changes (both sides of the blower have gearboxes). For AD1200 and smaller size pumps, the bearing housings of both sides are interconnected. For the AD2600 and larger sizes, the bearing housings of both sides are separated and each is provided with an oil sight glass respectively.

We recommend using Airtech's ATO-3000 oil, which can be obtained from Airtech.

Caution: Do not fill the oil sump when the pump is running

The correct oil level should be maintained between the two marks at the oil sight glass (Figure 7, Position 2) when the pump is running. If the oil level is too low, the bearings and gearwheels are not lubricated adequately; if it is too high, too much oil would cause higher than normal oil temperature, resulting in premature failure of the oil.

We recommend that the oil in the new pump should be changed after the first 500 hours of operation. Then, under normal operating conditions, change the oil after every 3000 hours of operation. Change the oil more frequently if pumping corrosive vapors or large amounts of dust or where excessive operating temperatures encountered.

1. Unscrew the oil-drain screws (Figure 7, Position 3) or (Figure 7, Position 5) and the oil-fill screw (Figure 7 Position 1) or (Figure 7, Position 4) and drain the oil.
2. Clean the sealing surface and firmly reinstall the oil-drain screw (Figure 7, Position 3) or (Figure 7, Position 5) using a brand new gasket. Wipe off any oil residue from the housing.
3. Fill with new oil.
4. Clean the oil-fill port and reinstall the screw (Figure 7, Position 1) or (Figure 7, Position 4) using a brand new gasket. Wipe off any oil residue from the housing.

The oil-fill and oil-drain port must be sealed tightly.

Caution: Before removing the oil-drain or oil-fill screw, be sure to switch off the pump and vent to atmospheric pressure.

During operation, the unit's housing and the oil temperature may exceed 80 °C. Allow the pump to cool before attempting maintenance. Always wear gloves to protect yourself against excessive temperatures and any harmful residues in the oil.

5.3 Cleaning the pumping chamber

In some applications, contaminants may be deposited and build up in the pumping chamber or on the rotors. After removing the inlet and outlet piping, the contaminants can be blown out with dry compressed air or flushed out with a suitable solvent.

Contaminants that cannot be blown or flushed out can be removed completely from the pumping chamber with a wire brush, metallic sponge or scraper.

During cleaning, the rotors should be turned by hand. Be sure the electrical current is removed from the motor prior to beginning the clean-out operation.

6 Troubleshooting

Issue	Possible Cause	Remedy	Repair
Pump does not start	Motor is connected incorrectly	Connect the motor correctly.	3.2
	Oil is too thick	Change the oil or warm the oil and the pump	5.2
	Motor rotor is malfunctioning	After sales service	-
	Pump has seized up: damaged rotors, bearings or gearwheels.	After sales service	-
Motor overloaded	Large foreign material entering pump housing	Remove any foreign material	5.3
	Overflow valve is blocked due to heavy rust	Dismount and clean the overflow valve and reassemble it in place	5.4
Pump gets too hot	Ambient temperature is too high or cooling water supply is obstructed.	Install the pump at a suitable site or maintain cooling water supply	2.2/3.1
	Pump is working in the wrong pressure range	Check pressure values of vacuum system	2.2/4.1
	Pressure differential is too great	Check pressure values of vacuum system	-
	Clearance between housing and rotors is too small due to: -contamination -distortion of pump	Clean the pumping chamber. Ensure that the feet and connecting lines aren't placing a strain on the pump	5.3 3.1
	Excessive frictional resistance due to contaminated bearings and/or oil	Change the oil	5.2
	Oil level is too high	Drain oil until it is at the correct level	5.2
	Oil level is too low	Add oil	5.2
	Wrong oil has been used	Drain oil and fill with correct lubricant	5.2
	Bearings are malfunctioning	After sales service	-
	Overflow valve is malfunctioning	Clean or repair the valve	5.4
Power consumption of the motor is too high	See "pump gets too hot" issue	See "pump gets too hot" issue	-
	Wrong main voltage supply for motor	Connect the motor to the correct voltage supply	2.2
	Motor is malfunctioning	Repair the motor or exchange it	-
	Oil is too thick	Change the oil or warm up the oil and the pump	-

Issue	Possible Cause	Remedy	Repair
Pump is too loud	Clearance between casing and impellers is too small due to: -contamination -distortion of pump	Clean the pumping chamber. Ensure that the feet and connecting lines aren't placing a strain on the pump	5.3 3.1
	Bearing or gearing is damaged	After sales service. Switch off the pump immediately.	-
	Rotors strike the housing	After sales service. Switch off the pump immediately.	-
	??	After sales service. Switch off the pump immediately.	-
	Overflow valve is tripping	Start the pump under a permissible cut-in pressure	4.1
Oil turns dark	Oil has broken down	Change the oil	5.2
	Pump gets too hot	See "pump gets too hot" issue. After solving the problem change the oil.	-
Pumping speed of the pump is too low.	Motor fault	After sales service	-
	Pump or connected system has a leak	Find and seal the leak	-
	Poise washer in the overflow valve is damaged	Replace the poise washer	5.4
	Flow resistance in the intake or discharge line is too high	Use intake and discharge lines of sufficient diameter	-
	Screws on the pump are loose	Retighten the screws	-
	Filter screen in the intake flange is clogged	Clean the filter screen	-
	Motor is connected incorrectly	Check the rotation direction and connect the motor correctly	3.2

7. Exploded View Drawings and Parts Lists

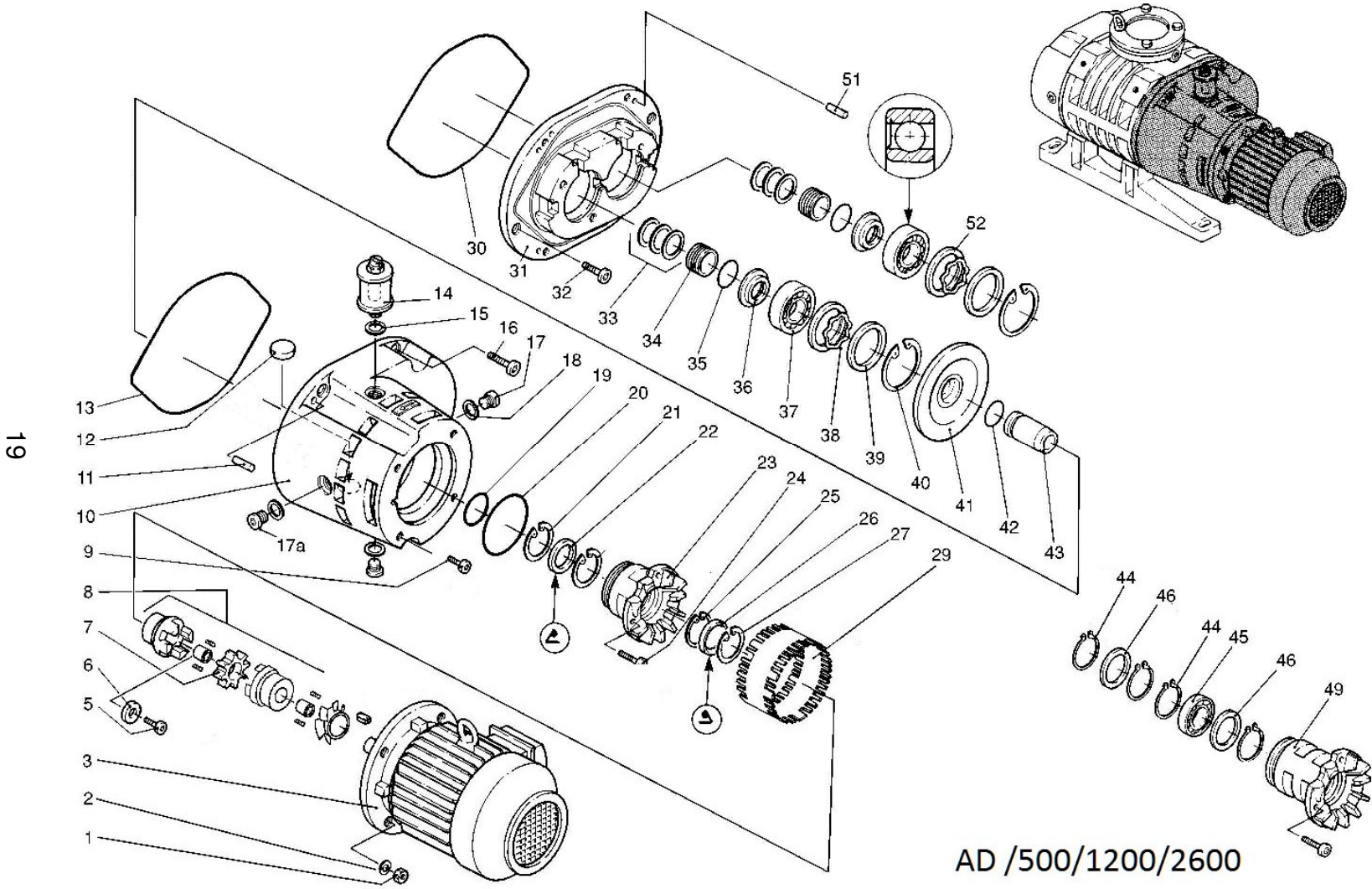

AD /500/1200/2600

PARTS LIST

Pos.	Quantity			Description	Pos.	Quantity			Description
	AD500	AD1200	AD2600			AD500	AD1200	AD2600	
1	4			Hex nut	29			1	Protective tube
1		4	4	Hex nut	30				O-ring
2	4			Washer	30	1			O-ring
2		4	4	Washer	30		1		O-ring
3				AD-Motor 3 phase	30			1	O-ring
3	1			AD-Motor 3 phase	31				Front end plate
3		1		AD-Motor 3 phase	31	1			Front end plate
3			1	AD-Motor 3 phase	31		1		Front end plate
5	1			Cylinder screw	31			1	Front end plate
5		1	1	Cylinder screw	32	2			Cylinder screw
6	1			Washer	32		4		Cylinder screw
6		1	1	Washer	32			4	Cylinder screw
7	1			Coupling element	33				Piston ring
7		1	1	Coupling element	33	6			Piston ring
8				Coupling compl.	33		8		Piston ring
8	1			Coupling compl.	33			8	Piston ring
8		1		Coupling compl.	34				Piston ring holder
8			1	Coupling compl.	34	2			Piston ring holder
9	4			Cylinder screw	34		2		Piston ring holder
9		4		Cylinder screw	34			2	Piston ring holder
9			4	Cylinder screw	35				O-ring
10				Motor flange	35	2			O-ring
10	1			Motor flange	35		2		O-ring
10		1		Motor flange	35			2	O-ring
10			1	Motor flange	36				Splash ring
11	2			Cylinder pin	36	2			Splash ring
11		2		Cylinder pin	36		2		Splash ring
11			2	Cylinder pin	36			2	Splash ring
12	1	1	1	Magnet	37				Ball bearing
13				O-ring	37	2			Ball bearing
13	1			O-ring	37		2		Ball bearing
13		1		O-ring	37			2	Ball bearing
13			1	O-ring	38				Elastic shims
14	1			Oil cup	38	2			Elastic shims
14		1	1	Oil cup	38		2		Elastic shims
15	1	1	1	Gasket ring	38			2	Elastic shims
16	4			Cylinder screw	39				Supporting plate
16		8		Cylinder screw	39	2			Supporting plate
16			8	Cylinder screw	39		2		Gauge disc
17	3	3	3	Plug screw	39			2	Gauge disc
18	3	3	3	Gasket ring	40				Circlip
19	1			O-ring	40	2			Circlip
19		1	1	O-ring	40		2		Circlip
20	1			O-ring	40			2	Circlip
20		1	1	O-ring	41				Oil splash duct
21	1			Circlip	41	1			Oil splash duct
21		1	1	Circlip	41		1		Oil splash duct
22	1			Radial shaft seal	41			1	Oil splash duct
22		1	1	Radial shaft seal	42	1			O-ring
23	1			Shaft seal housing	42		1	1	O-ring
23	1			Shaft seal housing	43	1			Bushing
23	1			Shaft seal housing	43		1	1	Bushing
23		1	1	Shaft seal housing	44		1	1	Circlip
24	4	1	4	Cylinder screw	45		1	1	Ball bearing
25	1			Circlip	46		1		Radial shaft seal
26	1			Radial shaft seal	46			1	Radial shaft seal
26		1	1	Radial shaft seal	49		1	1	Shaft seal housing
27	1			Felt disk	50		1	1	Gauge disc
27		1	1	Felt disk	51				Cylinder pin
28	1			Circlip	51	2			Cylinder pin
28		1	1	Circlip	51		2		Cylinder pin
29				Protective tube	51			2	Cylinder pin
29	1			Protective tube	52		2		Gauge disc
29		1		Protective tube	52			2	Gauge disc

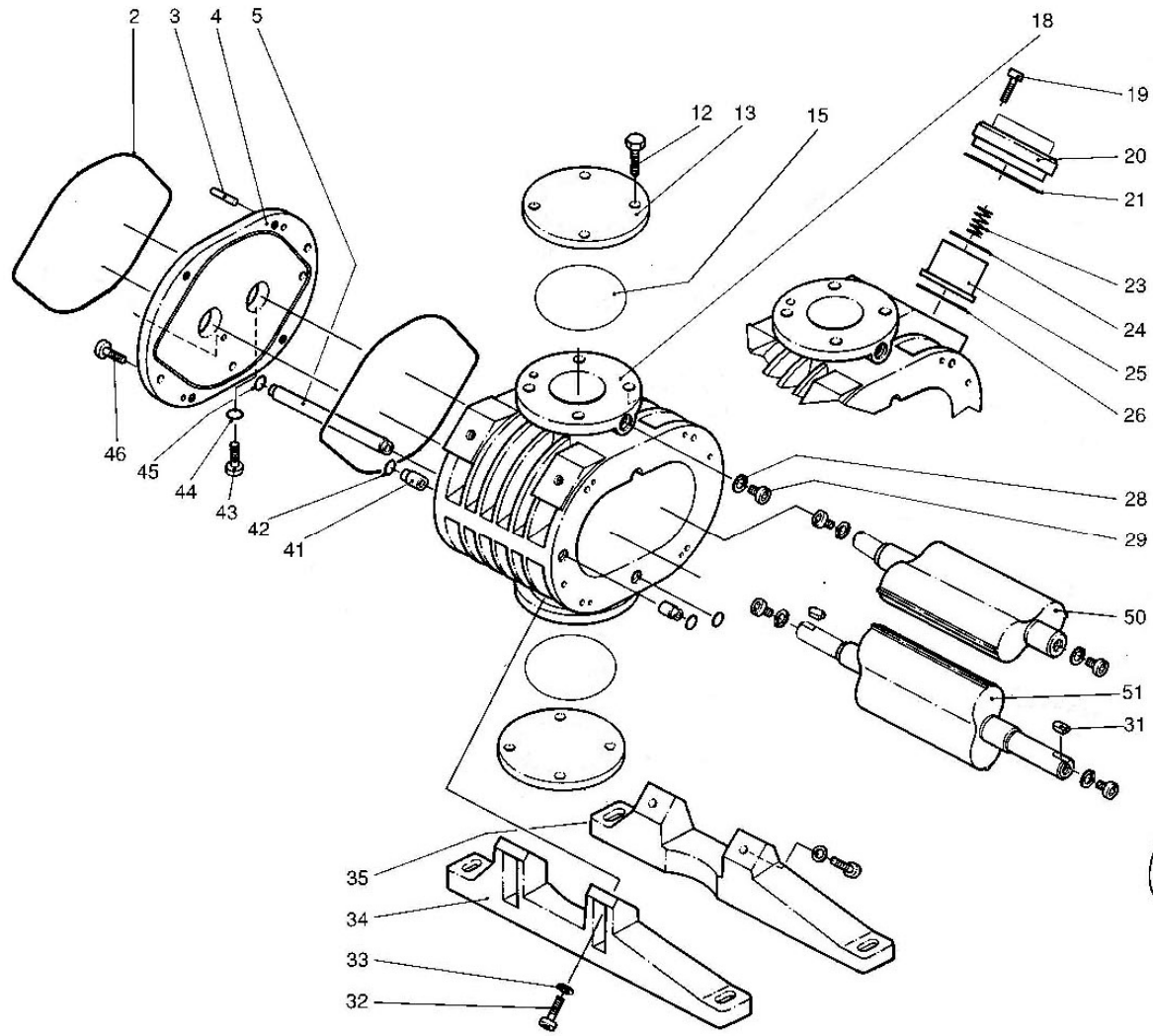

AD /500/1200/2600

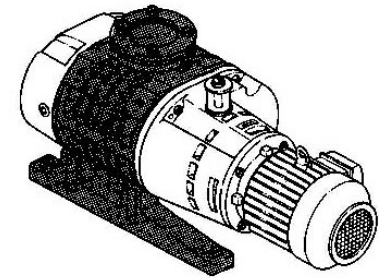

PARTS LIST

Pos.	Quantity			Description	Pos.	Quantity			Description
	AD500	AD1200	AD2600			AD500	AD1200	AD2600	
1	4			Hex nut	29			1	Protective tube
1		4	4	Hex nut	30				O-ring
2	4			Washer	30	1			O-ring
2		4	4	Washer	30		1		O-ring
3				AD-Motor 3 phase	30			1	O-ring
3	1			AD-Motor 3 phase	31				Front end plate
3		1		AD-Motor 3 phase	31	1			Front end plate
3			1	AD-Motor 3 phase	31		1		Front end plate
5	1			Cylinder screw	31			1	Front end plate
5		1	1	Cylinder screw	32	2			Cylinder screw
6	1			Washer	32		4		Cylinder screw
6		1	1	Washer	32			4	Cylinder screw
7	1			Coupling element	33				Piston ring
7		1	1	Coupling element	33	6			Piston ring
8				Coupling compl.	33		8		Piston ring
8	1			Coupling compl.	33			8	Piston ring
8		1		Coupling compl.	34				Piston ring holder
8			1	Coupling compl.	34	2			Piston ring holder
9	4			Cylinder screw	34		2		Piston ring holder
9		4		Cylinder screw	34			2	Piston ring holder
9			4	Cylinder screw	35				O-ring
10				Motor flange	35	2			O-ring
10	1			Motor flange	35		2		O-ring
10		1		Motor flange	35			2	O-ring
10			1	Motor flange	36				Splash ring
11	2			Cylinder pin	36	2			Splash ring
11		2		Cylinder pin	36		2		Splash ring
11			2	Cylinder pin	36			2	Splash ring
12	1	1	1	Magnet	37				Ball bearing
13				O-ring	37	2			Ball bearing
13	1			O-ring	37		2		Ball bearing
13		1		O-ring	37			2	Ball bearing
13			1	O-ring	38				Elastic shims
14	1			Oil cup	38	2			Elastic shims
14		1	1	Oil cup	38		2		Elastic shims
15	1	1	1	Gasket ring	38			2	Elastic shims
16	4			Cylinder screw	39				Supporting plate
16		8		Cylinder screw	39	2			Supporting plate
16			8	Cylinder screw	39		2		Gauge disc
17	3	3	3	Plug screw	39			2	Gauge disc
18	3	3	3	Gasket ring	40				Circlip
19	1			O-ring	40	2			Circlip
19		1	1	O-ring	40		2		Circlip
20	1			O-ring	40			2	Circlip
20		1	1	O-ring	41				Oil splash duct
21	1			Circlip	41	1			Oil splash duct
21		1	1	Circlip	41		1		Oil splash duct
22	1			Radial shaft seal	41			1	Oil splash duct
22		1	1	Radial shaft seal	42	1			O-ring
23	1			Shaft seal housing	42		1	1	O-ring
23	1			Shaft seal housing	43	1			Bushing
23	1			Shaft seal housing	43		1	1	Bushing
23		1	1	Shaft seal housing	44		1	1	Circlip
24	4	1	4	Cylinder screw	45		1	1	Ball bearing
25	1			Circlip	46		1		Radial shaft seal
26	1			Radial shaft seal	46			1	Radial shaft seal
26		1	1	Radial shaft seal	49		1	1	Shaft seal housing
27	1			Felt disk	50		1	1	Gauge disc
27		1	1	Felt disk	51				Cylinder pin
28	1			Circlip	51	2			Cylinder pin
28		1	1	Circlip	51		2		Cylinder pin
29				Protective tube	51			2	Cylinder pin
29	1			Protective tube	52		2		Gauge disc
29		1		Protective tube	52			2	Gauge disc

AD /500/1200/2600

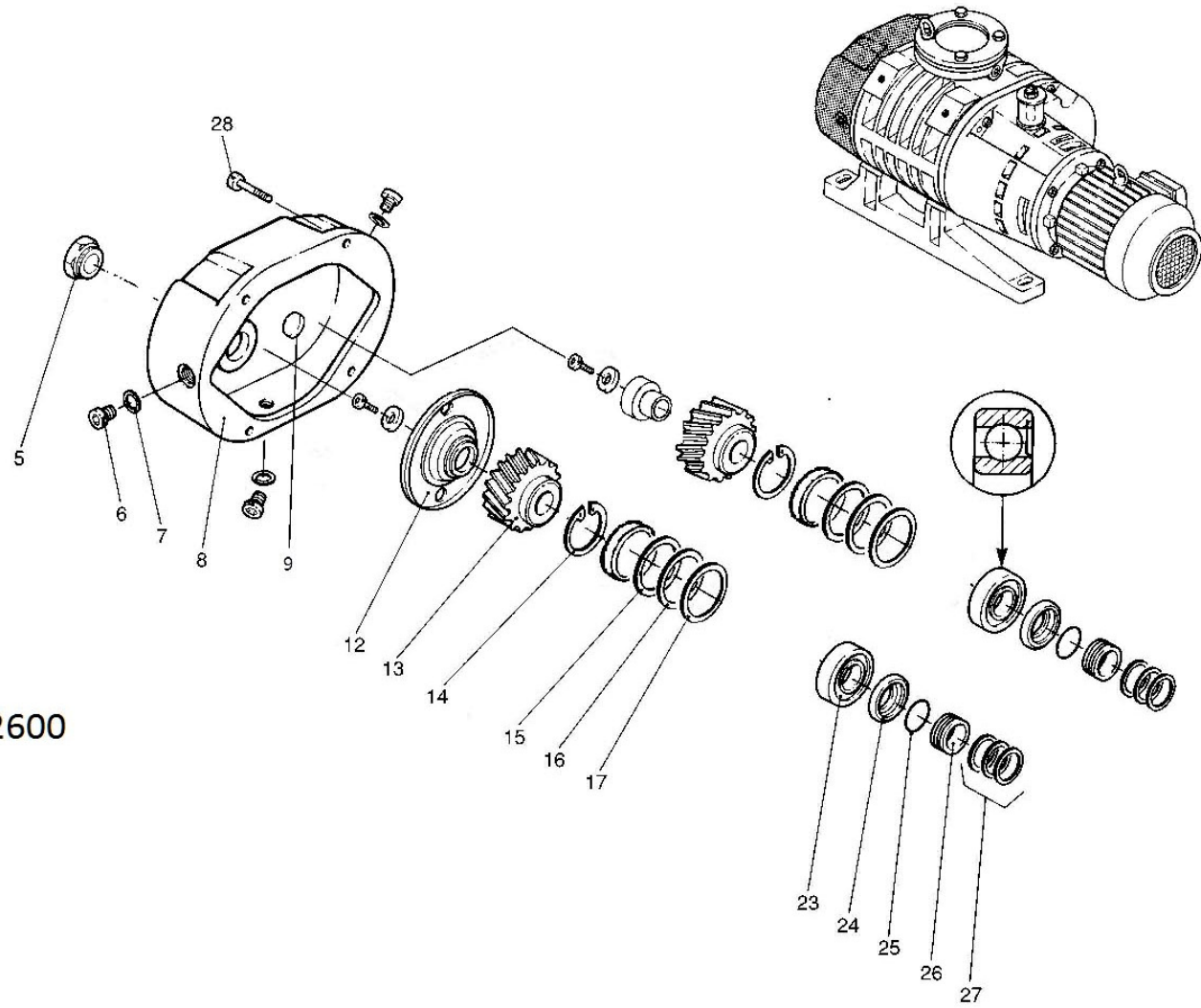

PARTS LIST

Pos.	Quantity			Description	Pos.	Quantity			Description
	AD500	AD1200	AD2600			AD500	AD1200	AD2600	
5	1	1	1	Sight glass	23	2			Ball bearing
6	3	3	3	Plug screw	23		2		Ball bearing
7	3	3	3	Gasket ring	23			2	Ball bearing
8				Housing cover	24				Splash ring
8	1			Housing cover	24	2			Splash ring
8		1		Housing cover	24		2		Splash ring
8			1	Housing cover	24			2	Splash ring
9	1	1	1	Magnet	25				O-ring
12				Oil splash duct	25	2			O-ring
12	1			Oil splash duct	25		2		O-ring
12		1		Oil splash duct	25			2	O-ring
12			1	Oil splash duct	26				Piston ring holder
13				Pair of gearwheels	26	2			Piston ring holder
13	1			Pair of gearwheels	26		2		Piston ring holder
13		1		Pair of gearwheels	26			2	Piston ring holder
13			1	Pair of gearwheels	27				Piston ring
14				Circlip	27	6			Piston ring
14	2			Circlip	27		8		Piston ring
14		2		Circlip	27			8	Piston ring
14			2	Circlip	28	4			Cylinder screw
15		2		Supporting plate	28		8		Cylinder screw
15			4	Supporting plate	28			8	Cylinder screw
16				Gauge disc	26			2	Piston ring holder
16	4			Gauge disc	27				Piston ring
16		2		Gauge disc	27	6			Piston ring
16			4	Gauge disc	27		8		Piston ring
17				Gauge disc	27			8	Piston ring
17	2			Gauge disc	28	4			Cylinder screw
17		2		Gauge disc	28		8		Cylinder screw
17			2	Gauge disc	28			8	Cylinder screw
23				Ball bearing					

10 Dimensional Drawing

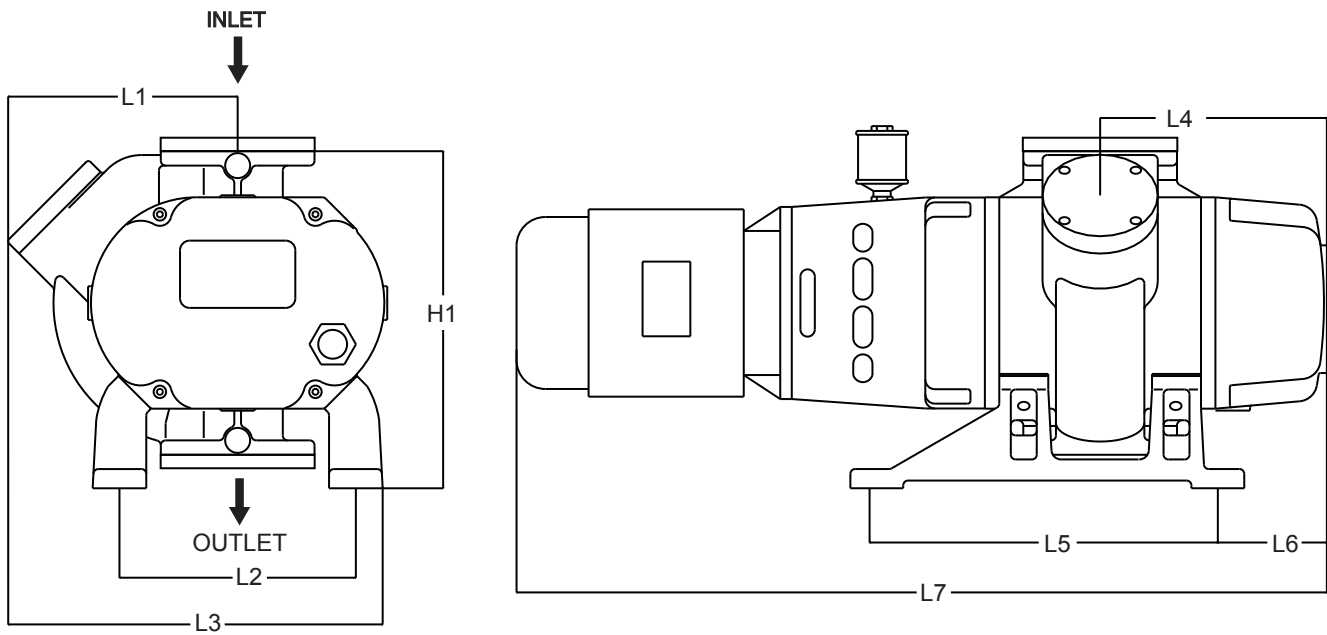

Model	L1	L2	L3	L4	L5	L6	L7	H1	INLET (NPT)	OUTLET (NPT)
AD500	9.37	9.68	15.55	9.29	14.56	4.17	33.26	13.77	3"	3"
AD1200	11.88	10.82	19.48	12.24	20.07	5.47	42.51	16.49	4"	4"
AD2600	16.14	15.27	25.27	14.44	29.13	5.90	48.66	20.86	6"	4"

Airtech, Inc. (“Company”) Warranty Statement

Company warrants that on the date of shipment to Purchaser the goods will be of the kind and quality described herein, merchantable, and free of all defects in workmanship and materials.

If within one year from the date of initial operation, but not more than eighteen months from date of shipment by the Company, of any item of the goods, Purchaser discovers that such item was not as warranted above and promptly notifies Company in writing thereof, Company shall remedy such defect by, at the Company’s option, adjustment, repair or replacement of the item and any affected part of the good. Purchaser shall assume all responsibility and expense for removal, reinstallation and freight in connection with the foregoing remedy. The same obligations and conditions shall extend to replacement items furnished by the Company hereunder. Company shall have the right of disposal of items replaced by it. Purchaser shall grant Company access to the goods at all reasonable times in order for Company to determine any defect in the goods. In the event that adjustment, repair or replacement does not remedy the defect, the Company and Purchaser shall negotiate in good faith an equitable adjustment in the contract price.

The Company’s responsibility does not extend to any item of the goods which has not been manufactured and sold by the Company. Such item shall be covered only by the express warranty, if any, by the manufacturer thereof. The Company and its suppliers shall also have no responsibility if the goods have been improperly stored, handled or installed, or if the goods have not been operated or maintained according to their ratings or according to the instructions in Company or supplier furnished manuals, or if unauthorized repairs or modifications have been made to the goods.

THIS WARRANTY IS EXPRESSLY IN LIEU OF ALL OTHER WARRANTIES (EXCEPT TITLE) INCLUDING BUT NOT LIMITED TO IMPLIED WARRANTIES OF MERCHANTABILITY AND FITNESS, AND CONSTITUTES THE ONLY WARRANTY OF COMPANY WITH RESPECT TO THE GOODS.

The forgoing states Purchaser’s exclusive remedy against Company and its suppliers for any defect in the good or for failure of the goods to be as warranted, whether Purchaser’s remedy is based on contract, warranty, failure of such remedy to achieve its essential purpose, tort (including negligence), strict liability, indemnity, or any other legal theory, and whether arising out of warranties, representations, instructions, installations, or defects from any cause.

Neither Company nor its suppliers shall be liable, whether in contract, warranty, failure of a remedy to meet its essential purpose, tort (including negligence), strict liability, indemnity or any other legal theory, for loss of use, revenue or profit or for cost of capital or of substitute use or performance or for indirect, liquidated, incidental or consequential damages or for any other loss or cost of a similar type, or for claims by Purchaser for damages of Purchaser’s customers.

AIRTECH[®]
VACUUM

301 Veterans Boulevard
Rutherford, NJ 07070
Tel: 1 888 222 9940
Fax: 201 569 1696
airtech@airtechusa.com

AIRTECH[®] SOUTH
VACUUM

2121 Newmarket Pkwy. Suite 110
Marietta, GA 30067
Tel: 770 690 0700
Fax: 770 690 0709
airtechsouth@airtechusa.com

AIRTECH[®] WEST
VACUUM

42 Digital Drive #9
Novato, CA 94949
Tel: 415 382 9000
Fax: 415 382 9700
airtechwest@airtechusa.com

AIRTECH[®]
CHINA

2nd Building,
Jiangbian Second Industrial Park
Songgang Town, Bao'an District
Shenzhen, China
Tel: +86 755 81730991(Ext.8018)
Fax: +86 755 81730986
www.airtechchina.com



10 / 9 Sainsbury Road
O'Connor 6163
WA
Australia
Tel: +61 8 9304 6121
Fax: +61 8 9331 4813
www.vacuvane.com.au

AIRTECH[®]
EUROPE

Vacuvane
Vacuum Technology GMBH
Pfaffenpfad 5
D-97440 Werneck
Germany
Tel: +49 9722 943 96 0
Fax: +49 9722 943 96 29
www.vacuvane.com

AIRTECH[®]
EUROPE

HPE
Pressure & Vacuum Technology
C. dels Amics d'Argentona, 40
08310 Argentona (Barcelona)
Spain
Tel: +34 93 797 17 66
Fax: +34 93 797 17 54
www.hpe-technology.com